

HAIMER®
以质取胜.

翰默热缩机 POWER CLAMP

热缩机技术
Shrink fit technology



www.haimer.cn

目录 CONTENTS

The Power Clamp System/热缩机系统	
使用 HAIMER 翰默热缩机技术的十大理由/Top 10 Reasons to Use HAIMER Shrink Fit Technology	3
接触式冷却/The Contact Cooling	4
线圈科技/The Coil Technology	5
HAIMER 翰默热缩机的优势/Amortisation HAIMER Power Clamp	8
基本系列、增强系列和工业 4.0 系列热缩机的区别/Differentiation Basic Line/Profi Line/i4.0 Line	9
设备特征/Equipment Features	12
Power Clamp Basic Line/基本系列热缩机	
Nano 纳米型热缩机/Power Clamp Nano	14
Smart 智能型热缩机/Power Clamp Smart	16
基本型热缩机/Power Clamp Basic	18
Power Clamp Profi Line/增强系列热缩机	
模块化系统/The Modular System	20
增强系列热缩机的产品线/Power Clamp Profi Line Program	22
翰默新一代热缩机/HAIMER Power Clamp New Generation	24
经济型/NG 经济型热缩机/Power Clamp Economic/Economic NG	26
经济增强型/NG 经济增强型热缩机/Power Clamp Economic Plus/Economic Plus NG	28
特殊配置经济增强型热缩机/Power Clamp Economic Plus Special Edition	30
舒适型/NG 舒适型热缩机/Power Clamp Comfort/Comfort NG	32
NG 强力型热缩机/Power Clamp Profi Plus NG	34
NG 测量型热缩机/Power Clamp Preset NG	36
超级增强型热缩机/Power Clamp Premium Plus	38
Power Clamp i4.0 Line/工业 4.0 系列热缩机	
工业 4.0 热缩机技术就绪/Shrink Fit Technology Industry 4.0-ready	40
工业 4.0 系列热缩机的亮点/Power Clamp i4.0 Line Highlights	42
工业 4.0 系列热缩机的冷却系统/Power Clamp i4.0 Line Cooling	43
工业 4.0 纳米型NG热缩机/Power Clamp Nano NG i4.0	44
工业 4.0 气冷经济型热缩机/Power Clamp Air i4.0 Eco	46
工业 4.0 气冷舒适型热缩机/Power Clamp Air i4.0 Comfort	48
工业 4.0 舒适型热缩机/Power Clamp Comfort i4.0	50
工业 4.0 测量型热缩机/Power Clamp Preset i4.0	52
工业 4.0 超级型热缩机/Power Clamp Premium i4.0	54
工业 4.0 全能型热缩机/Power Clamp Sprint i4.0	56
Accessories/附件	
工具车和插件/Carts and Inserts	58
支撑座/Base Holder	59
支撑盘/Chuck Support	61
精密支撑盘/Precision Chuck Support	63
旋转支撑盘/CHUCK SUPPORT FOR ROTARY TABLE	65
ER 热缩筒夹用支撑盘/Chuck Support for ER Shrink Fit Collets	66
简易长度预调装置/SIMPLE PRESETTING	68
快速长度预调装置/Length Presetting	69
冷却转换套和冷却转换套毛坯/Cooling Adapter and Cooling Adapter Blanks	70
迷你型热缩刀柄用安装冷却保护套/Mini Shrink Shrink and Cooling Sleeves	71
带温控的冷却系统/TME Cooling System with Temperature Control	72
热缩刀柄调节长度用支撑弹簧/Tension Springs for Length Presetting for Shrink Fit Chucks	73
断刀取出装置/Shrink-Out Device	74
热缩刀柄用清洁毛刷/Shrink Fit Brush	75
热缩刀柄用减径套/Reduction Sleeves for Shrink Fit Chucks	76
废气吸收装置/Auxiliary Fume Extraction Unit	77
13 kW HD 重型线圈升级套装/Upgrade Kit 13 kW HD Coil	78
止动盘/Stop Discs	79

使用 HAIMER 翰默热缩机技术的十大理由

Top 10 Reasons to Use HAIMER Shrink Fit Technology

1

很高的夹持精度

我们保证在 3 倍径的悬升长度处的径跳 < 0.003mm，无论谁来操作，这个精度都是稳定且可重复的。

Unsurpassed machining accuracy

We guarantee < 3µm run-out at 3xD. This degree of accuracy is consistently repeatable for any number of operators from shift to shift.

2

苗条的外形——尤其适用于五轴机床

翰默热缩刀柄的外形很苗条。为了防止在使用中和工件干涉，它们甚至可以改制为直壁结构。

Slim profiles – perfect for 5-axis machining

HAIMER Shrink Fit tool holders have very slim profiles. They can also be modified to a straight-walled design if needed in order to prevent tool holder collision with the workpiece.

3

夹持力

我们的热缩刀柄在 360° 的方向上夹紧刀具柄部，能够传递很大的扭矩，防止其在粗加工和精加工中的振动。

Gripping torque

Our shrink fit chucks grip the cutting tool 360° around the shank on multiple planes, delivering very high gripping torque that prevents chatter during roughing or finishing operations.

4

装配的一致性

翰默热缩刀柄的一个独特的优势是它消除了换刀过程中的所有变量。消除这些变量意味着无论谁来操作以及他们的技术水平如何，您都将获得可重复的刀具安装和一致的结果。

Consistency of setup

A unique benefit of HAIMER shrink fit is that it eliminates any variation between tool changes. Removing these variables means regardless of the operator and their experience level, you will get repeatable uniformity in tooling setup and equally consistent results.

5

延长悬升长度

热缩延长杆可以提供很多长度的选择。例如：在加工深腔时，您可以将热缩延长杆装入标准热缩刀柄中，在保证很小的径跳的同时，获得很长的悬升长度。

Extended reach options

Shrink fit extensions provide many options. For example, when machining deep cavities, you can place shrink fit extensions into standard shrink fit chucks, getting unsurpassed gage lengths with minimal run-out.

6

动平衡精度和重复精度

我们的热缩刀柄出厂时的动平衡精度为 G2.5@25,000 rpm。由于热缩刀柄没有运动部件，它的动平衡重复精度远超市场上的其他夹持系统。

Balance accuracy and repeatability

We hold our shrink fit holders to the highest balance accuracy standards (G2.5@ 25,000 RPM). Since shrink fit holders have no moving parts, it offers the best balance repeatability of any tool holding system on the market.

7

减少换刀时间和附件的库存量

配合我们的强力热缩机，我们的热缩刀柄的换刀时间很短，可以在 5 秒内完成换刀。

Reduction of tool changing time & less tool holder accessory inventory

Nothing beats the tool change time of our shrink fit chucks when combined with the HAIMER Power Clamp shrink fit machines. Tool changes can be done in less than 5 seconds.

8

清洁的夹持孔

刀柄的夹持孔在使用时会沾染一些污染物，从而导致刀具的径跳误差加大。而热缩夹持系统是设计为封闭的，将污染物的影响尽可能地减小了。

Clean bores

Run-out accuracy is often compromised if contaminants are introduced to the bore of a tool holder during machining. A shrink fit chuck is a sealed system by design. This minimizes the introduction of contaminants.

9

冷却液传输方式的选择

我们的热缩刀柄有很多冷却方式的选择，包括我们的冷却喷孔和环绕冷却技术，可以将冷却液直接输送至刀刃。这将有助于排屑并获得更好的工件表面质量。

Coolant options

Our shrink fit chucks are available with a variety of coolant options, including our Cool Jet and Cool Flash technology, which delivers coolant down to the cutting edge of the tool. This helps clean out chips and can aid in providing better part finishes.

10

充足的库存

我们大多数的产品都有库存，包括热缩机及各种接口和型号的刀柄。我们还提供各种刀柄改制服务，也可以在短时间内交货。

Availability

Bestseller machines are available and stocked locally. All other configurations and modifications are available per order within just a couple of weeks. Shrink fit holders are available on stock in a big variety of lengths in the most common spindle interfaces.

接触式冷却 The Contact Cooling

翰默专利的冷却系统 (发明专利号码: EP 2 346 642 B1*), 快速且清洁的冷却方式。每个刀柄都有适合的冷却套, 冷却套安放在刀柄上与外表面接触, 将热量带走。冷却水在冷却套内循环流动。

整个冷却过程温和且均衡, 刀柄无任何变形, 跳动精度被保证。刀柄不会与冷却水接触, 保证干燥不会生锈, 工作环境干净整洁。

The patented cooling system from HAIMER is the quickest and cleanest method of cooling shrink fit chucks. There is a suitable cooling body for every chuck. The cooling body sits with the surface contact on the chuck and removes the heat from it. A water cycle cools the cooling body in turn.

The cooling procedure takes place completely evenly and gently. There is no deformation of the chuck. The runout accuracy is preserved. The chucks do not come into contact with the water. They remain dry and do not rust. The work place also remains clean and dry.

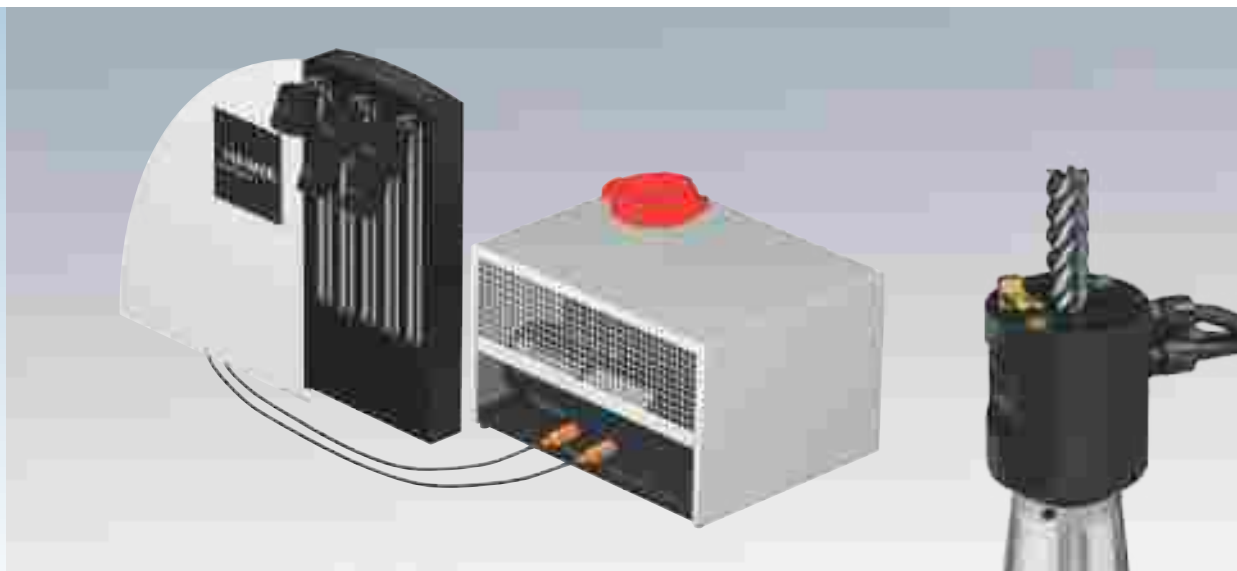

快速冷却的冷却套

- 冷却时间: 大约 30秒
- 刀柄保持干燥
- 防止生锈
- 无需花费时间烘干刀柄
- 刀柄冷却后, 径跳精度也保持不变
- 加热的部分总是被覆盖, 无烫伤危险
- 操作时无需接触高温部件
- 过程温和且安全, 不会发生意外
- 即使冷却了很多热缩刀具后, 冷却套也不会发热, 热量全部被冷却水循环带走
- 5个冷却套适合所有的标准刀柄
- 冷却水不会渗漏, 工作环境干净整洁

Cooling body for rapid cooling

- Cooling in record time: approx. 30 s
- Tool holders remain dry
- No build-up of rust
- No time lost through drying process
- Even cooling, runout accuracy is maintained
- Hot points are always covered, no risk of injury
- Hot parts need not be touched
- Gentle handling of chuck, no shocking
- No heating of cooling body, even after lots of shrink fit procedures: heat is removed with water cycle
- 5 cooling bodies for all standardized chucks
- No dripping water, always a clean work space

线圈技术 The Coil Technology

感应线圈是感应式热缩技术的核心。

翰默HAIMER 一直是感应式热缩技术的领导者。我们在感应线圈技术方面拥有的多项专利 (发明专利号码: CN 101189915 B*), 是我们创新和进步的显著证明。

电力科技

构成热缩技术的第二个要素是电力电子元件。它提供线圈电力, 精确地控制频率和电流大小。加热只需要几秒钟, 从而避免刀柄过热。翰默HAIMER 能提供从 10 KW 到 33 KW 功率的热缩机。

操作

投资成功的决定性因素是能被员工接受, 如果一台机器能被频繁并愉快地使用, 即能在短时间内收回投资。翰默 HAIMER 的热缩设备能符合用户的各种需求, 客户可以购买不带冷却系统的入门级热缩机, 或者购买整套热缩机设备, 包括接触式冷却水套系统和可旋转的支撑盘以及工具车。



The induction coil is the core of inductive shrink fit technology. HAIMER has been the leading developer of inductive shrink fit technology for tool holders for years. A number of patents, predominantly in the field of induction coils, is the visible proof of our innovation and advancement.

Power electronics

The second component of shrink fit technology is power electronics. It supplies the coil with power. Frequency and current must be exactly coordinated with one another to do this. Heating must take place within seconds, without overheating the chuck. A specially developed procedure for power regulation makes sure this is the case, independent of the main voltage. HAIMER offers shrink fit equipment with an output of 10 to 33 kW.

Operation

Equally decisive for the success of an investment is its acceptance among your employees. A machine, which is used happily and frequently, pays for itself within a short period of time. HAIMER shrink fit equipment can be equipped for any purpose and need. From a simple device with one shrink fit station and no cooling, up to fully equipped machines with rotary table, integrated contact cooling and system cart.

翰默线圈产品图示/Examples of HAIMER coils:

- 1) 标准线圈V2008/Standard coil V2008
- 2) 带废气吸收装置的自动NG线圈
Motorised New Generation Coil with auxiliary fume extraction unit
- 3) 13 kW HD 重型线圈/13 kW HD coil

*如需更多关于翰默专利的信息, 请联系翰默(上海)贸易有限责任公司。

标准线圈

The Standard Coils

带可更换止动盘的标准线圈已应用许多年，夹持孔直径从 Ø3-32mm 的热缩刀柄可以通过一个线圈加热以装拆。只需要五个止动盘就能使该线圈适用于直径从最小到最大的各种热缩刀柄。

The standard coils have been proven for years with interchangeable stop disks. All shrink fit chucks with a diameter of 3 to 32 mm can be heated with a single coil. Just 5 stop disks are enough to adapt the coil to each chuck, from the smallest to the largest.



标准线圈

依托超过20年的热缩机感应线圈制造经验，翰默的标准线圈已经发展成为热缩机设备上一个稳定且高效的组成单元。通过智能控制，线圈仅加热选定的感应加热区域，可以更高效的加热刀柄，同时延长刀柄的使用寿命。

The standard coil

With over 20 years of experience in making inductive shrink fit machine coils, HAIMER has evolved our standard coil to be a very solid and efficient component on our machines. Through our intelligent control, the coil only activates the inductive zones that will most effectively heat up the shrink fit chuck in order to give long lasting tool holder life.

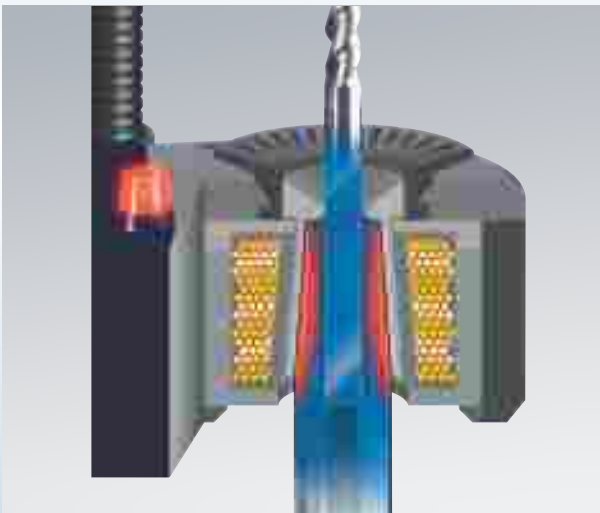

NG线圈

The New Generation (NG) Coils

智能 NG 型线圈使用特别灵活、舒适和方便。 NG线圈是可调的，用户可以转动线圈，调节线圈的高度和内径，来适应刀柄夹持孔的直径和长度。这意味着只加热需要加热的部分，对于特殊尺寸的刀柄也适用。NG 型线圈不再需要使用止动盘。

The intelligent NG coils are particularly flexible, comfortable and adjustable. With one turn, you can set the coil to the size of the shrink fit chucks, both in length and diameter. Stop disks are no longer necessary. This means the chuck is only heated where it is intended, even with special sizes.



NG线圈具有两个感应加热区域

在努力使加热过程更优化的探索中，翰默创新地设计出了含双层感应加热区域的智能NG线圈。这使得对热缩刀柄夹持部分的加热更均匀和高效，更好地延长了热缩刀柄的寿命。您在金属切削加工中使用超短型热缩刀柄有很多好处，而该智能线圈可以轻松用于加热超短型热缩刀柄。

The NG Coils have two heating zones

In an effort to maximize the efficiency of the heating process, HAIMER has a revolutionary two heating zone design in their NG (New Generation) intelligent coils. This allows for even and efficient heating across the nose of the shrink fit chuck – leading to longer tool holder life. These coils also can adapt themselves to ultra-short shrink fit chucks easily and ultra-short shrink fit chucks can often provide a benefit in the machining process.

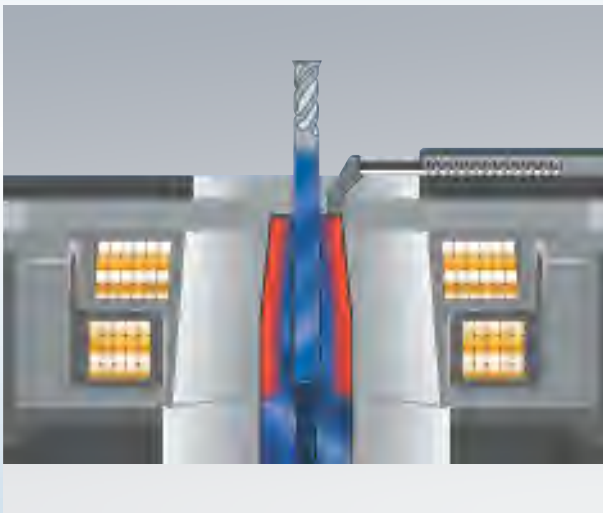

自动NG线圈

The motorised New Generation (NG) Coils

为了提供更便利和自动化的热缩过程，在翰默的工业4.0型热缩机上使用自动NG线圈时，我们强烈建议配置一把手持式扫码枪。

自动NG智能线圈可以通过电机自动调整线圈的加热直径以及高度来加热对应的热缩刀柄/热缩筒夹。

只需要扫描一下刀柄或热缩筒夹上的二维码，线圈会自动旋转到正确的加热位置。

将自动NG智能线圈放置在热缩刀柄/热缩筒夹的感应加热区域，通过启动按钮进行感应加热。

整个加热过程平滑、连贯和迅速。

For the most convenient and automated shrinking process the motorised NG coil on a HAIMER i4.0 shrink machine is highly recommended in conjunction with a hand scanner.

The intelligent, motorised NG coil adjusts automatically to the correct tool diameter and length for heating up the tool holder / shrink fit collet with the right parameters.

Just scan the tool holder or shrink fit collet's data-matrix code and the coil's motor starts to move the coil to the right position.

Place the motorised NG coil on the shrink fit chuck / collet and start inductive heating at the push of a button.

This leads to a very smooth, consistent and operator independent shrinking process.



图片显示的为带废气吸收装置的自动线圈(选配)
Picture shows motorised coil with auxiliary fume extraction unit (optional)

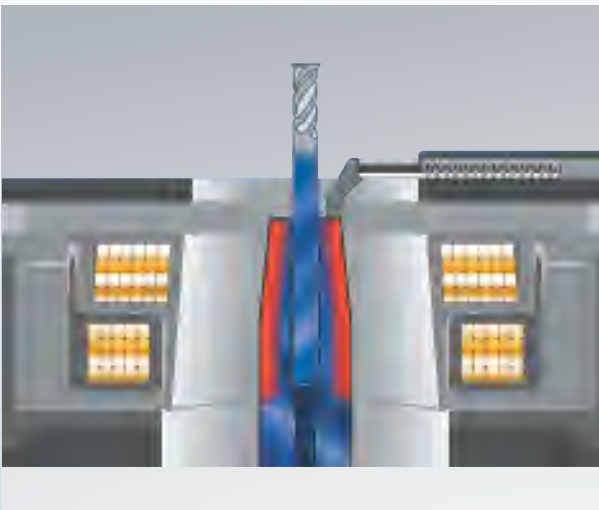

NG线圈具有两个感应加热区域

在努力使加热过程更优化的探索中，翰默创新地设计出了含双层感应加热区域的智能NG线圈。这使得对热缩刀柄夹持部分的加热更均匀和高效，更好地延长了热缩刀柄的寿命。您在金属切削加工中使用超短型热缩刀柄有很多好处，而该智能线圈可以轻松用于加热超短型热缩刀柄。

The NG Coils have two heating zones

In an effort to maximize the efficiency of the heating process, HAIMER has a revolutionary two heating zone design in their NG (New Generation) intelligent coils. This allows for even and efficient heating across the nose of the shrink fit chuck – leading to longer tool holder life. These coils also can adapt themselves to ultra-short shrink fit chucks easily and ultra-short shrink fit chucks can often provide a benefit in the machining process.

翰默 HAIMER 热缩机的成本摊销期
 AMORTISATION HAIMER POWER CLAMP

成本摊销期 Amortisation

购买价格

带冷却器的 N G型热缩机的成本
 摊销期取决于每天的使用次数。

节约的时间: 5分钟/每次
 成本设置: 50€/小时

Purchase price

Amortisation Power Clamp
 with Speed Cooler dependent on the number
 of shrink cycles per day.

Saving of time: 5 Min. per cycle
 Cost set: 50€/h

下图显示了热缩机的成本摊销期很短

The following diagram shows
 the short amortisation periods.

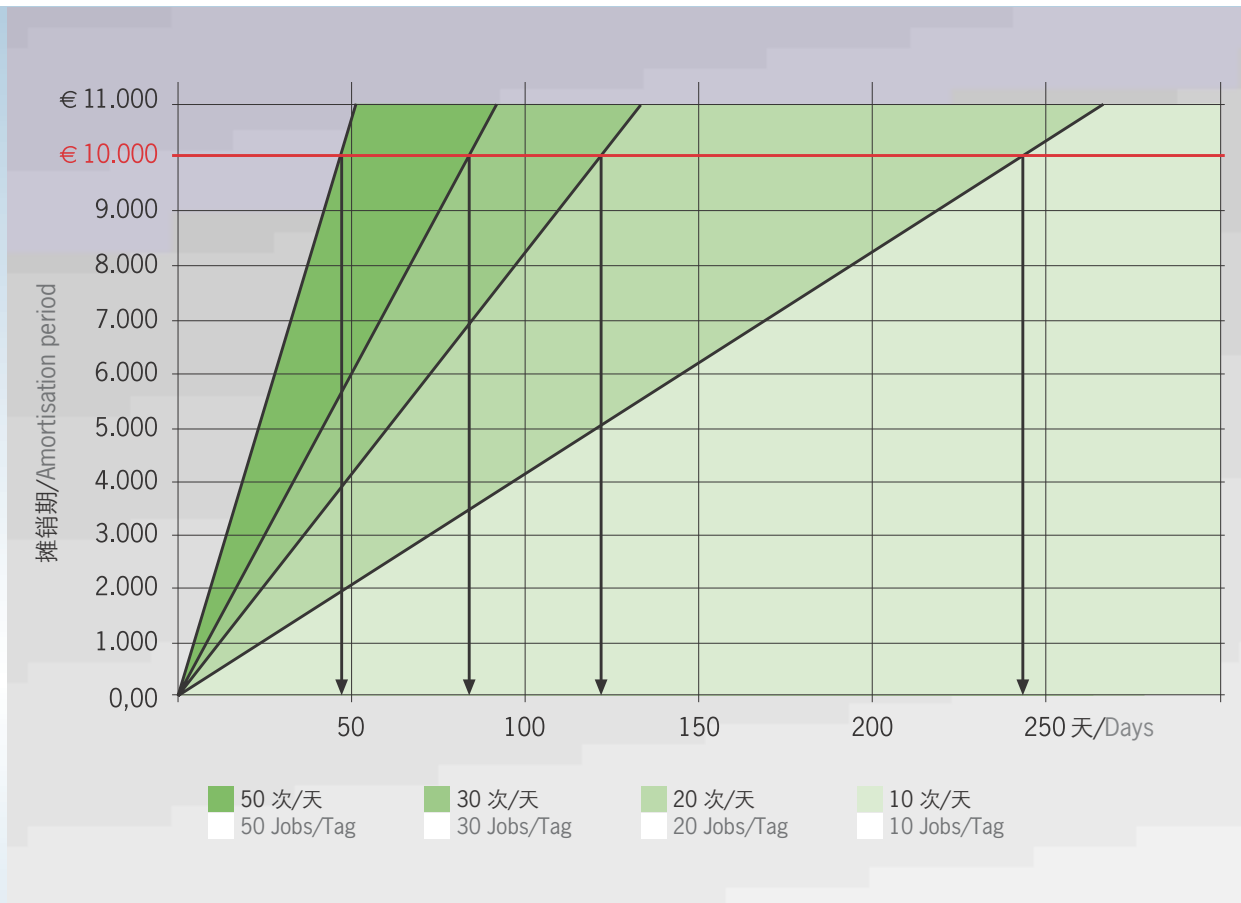

Basic Line / 基本系列 Profi Line / 增强系列 i4.0 Line / 工业 4.0 系列

翰默 HAIMER 的热缩机技术能够满足各种需求。
有众多的机型和线圈可供选择。

HAIMER has the right shrink fit technology for any need. Take advantage of the largest range of shrink fit equipment and coils in the world.



基本系列：关注基本应用

基本系列热缩机是感应热缩技术的入门级系列产品。其电力电子元件确保稳定的加热性能。而另一方面，该设备的机械结构也确保了其功能性和简易性。该设备仅支持单支撑座方案。基本系列设备是为标准型线圈特别设计的，不能升级。基本系列热缩机是预算有限且每天仅装拆几支刀具的客户的首选。该系列中的 NANO 纳米型热缩机是适用于微型刀具的卧式机型。它使微型刀具的装拆变得简单和快速。

Basic Line: Concentrating on the basics.

The Basic Line is the economical entrance into inductive shrink fit technology. The power electronics enables problem free shrinking. The mechanical construction of the equipment has, on the other hand, been kept deliberately simple and functional. There are just single chuck solutions.

The Basic Line equipment is exclusively designed for operation with standard coils. It is not possible to upgrade.

The Basic Line is ideal for the price-conscious user, who only wants to shrink a few tools on a daily basis.

For micro machining purposes the special horizontal shrink fit machine Power Clamp Nano is part of the program. It combines perfectly easy tool handling of small diameters and fast tool exchange.

翰默 HAIMER 热缩机系统 THE POWER CLAMP SYSTEM



增强系列：模块化的全能选手

增强系列热缩机能够满足各种功能和效率的需求。高性能线圈、冷却水套和旋转工作台确保了创纪录的同步加热和冷却。每一个客户的需求都得到了满足。增强系列热缩机可以配置标准线圈或者智能且舒适的 NG 线圈。当然，我们的设备可以自动识别每一个线圈并选择正确的加热程序。增强系列热缩机是一个模块化的系统。起步机型例如：经济型热缩机可以逐步升级至高端机型：NG 舒适型热缩机。

Profi Line: Modular All-rounder.

The Profi Line offers the full range of performance and is unbeatable in efficiency. High performance coils, contact cooling and rotary table guarantee simultaneous shrinking and cooling in record time. No wishes remain unfulfilled.

The machines of the Profi Line work with both the standard coils and the intelligent and comfortable NG coils. Of course, the equipment recognizes each coil and chooses the correct shrink fit parameters automatically.

The shrink fit machines of the Profi Line form a modular system. The start-up machine Power Clamp Economic can gradually be upgraded to the high-end unit Power Clamp Comfort NG.

工业 4.0 系列：兼容性好且便于沟通的网络

除了知名的基本系列和增强系列热缩机，我们还开发了全新的网络兼容性好的工业 4.0 系列，该系列有超级型、全能型、测量型和舒适型热缩机。这些设备配置了用户友好型 7" 触摸屏和新型且直观的软件，用户操作时戴着和不带手套都更简便。根据用户的需求，工业 4.0 系列热缩机可以配置扫码枪，因而可以读取二维码中的热缩参数。这使得自动化的加热操作比以往更简便了。这些符合人体工程学的新型热缩机都有时尚和高品质的设计。由于他们配置了翰默专利的 NG 线圈 (发明专利号：CN 101189915 B*)，适用于柄径为 3 至 32mm 的硬质合金和高速钢刀具。

i4.0 Line: Network-compatible and communicative.

In addition to the well-known machines of the Basic and Profi line, the all-new industry 4.0-ready and network-compatible series was developed with its models Power Clamp Premium i4.0, Sprint i4.0, Preset i4.0 and Comfort i4.0.

The machines are equipped with a workshop friendly 7" touch display and new intuitive software, which makes machine operation with or without gloves even easier. Upon request, the Power Clamp i4.0 devices can also be equipped with a scanner that is able to read the shrinking parameters of Data-Matrix codes. This way automated shrinking is easier than ever before.

The new and ergonomic shrinking stations have a modern and high-quality design. Due to their patented NG coil they are suited for both solid carbide and HSS tools with diameters from 3 to 32 mm.













设备特征 EQUIPMENT FEATURES

符号/ Symbol	系列/Line 内容/Feature	基本系列 /Basic Line			增强系列 /Profi Line				
		纳米型 Nano	智能型 Smart	基本型 Basic	经济型 Economic	NG 经济型 Economic NG	经济增强型 Eco Plus	NG 经济增 强型 Eco Plus NG	特殊配置经 济增强型 Special Edition
									
	单支撑座型 Single chuck version	●	●	●	●	●	●	●	●
	同步加热和冷却型 Cooling and Shrinking simultaneously	—	—	—	○	○	○	○	○
	旋转盘 Rotary table	—	—	—	○	○	○	○	—
	冷却系统 Cooling	○	—	—	○	○	●	●	●
	带冷却控制器的快速冷却器 Speed Cooler with Cooling Manager	—	—	—	○	○	●	●	●
	温度监控系统 TME Cooling system	—	—	—	—	—	○	○	—
	模块化系统 Modular system	—	—	—	●	●	●	●	—
	标准线圈 Standard coil	—	●	●	●	○	●	○	●
	多种 NG 线圈 Variable NG coil	—	—	—	○	●	○	●	○
	自动NG线圈 Intelligent motor coil	—	—	—	○	○	○	○	○
	13 kW 重型线圈 13 kW HD coil	—	—	—	○	○	○	○	○
	20 kW 线圈 20 kW coil	—	—	—	—	—	—	—	—
	5 键薄膜键盘 5 keys membrane keypad	●	●	●	●	●	●	●	●
	工业 4.0 配置 Industry 4.0 ready	—	—	—	—	—	—	—	—
	7" 触摸屏 7" Touchscreen	—	—	—	—	—	—	—	—
	手持式扫码枪 Hand-held scanner	—	—	—	—	—	—	—	—
	长度预调 Length presetting	○	—	—	○*	○*	○*	○*	—
	工具车 System cart	○	○	○	○	○	○	○	○
	废气吸收装置 Auxiliary fume extraction unit	—	—	○	○	○	○	○	○

* 只能与预调升级套装组合使用(订货号: 80.117.00)
Only available in combination with Preset Upgrade Kit (Order No. 80.117.00)

● 包含/included ○ 选配/optional — 没有/not available

设备特征 EQUIPMENT FEATURES

舒适型 Comfort	NG 舒适型 Comfort NG	NG 强力型 Profi Plus NG	NG 测量型 Preset NG	超级增强型 Premium Plus	工业 4.0 系列 /i4.0 Line						
					工业 4.0 纳米型 Nano NG i4.0	工业 4.0 气冷经济型 Air i4.0 Eco	工业 4.0 气冷舒适型 Air i4.0 Comfort	工业 4.0 舒适型 Comfort i4.0	工业 4.0 测量型 Preset i4.0	工业 4.0 超级型 Premium i4.0	工业 4.0 全能型 Sprint i4.0
											
—	—	—	—	—	•	•	•	—	—	—	—
•	•	•	•	•	—	•	•	•	•	•	•
•	•	•	—	—	—	—	—	•	—	—	—
•	•	•	•	•	•	•	•	•	•	•	•
•	•	•	•	•	—	•	•	•	•	•	—
○	○	○	○	•	—	•	•	○	○	•	•
•	•	•	•	—	—	•	•	○	○	—	—
•	○	○	○	○	—	○	○	○	○	○	○
○	•	•	•	○	—	•	○	•	•	•	•
○	○	○	○	•	•	○	•	○	○	○	○
○	○	○	○	○	—	○	○	○	○	○	○
—	—	○	—	•	—	—	—	—	—	—	—
•	•	•	•	•	—	—	—	—	—	—	—
—	—	—	—	—	•	•	•	•	•	•	•
—	—	—	—	—	•	○	•	○	○	○	○
○*	○*	○*	•	•	○	○	○	○	•	○	○
○	○	○	○	—	○	○	○	○	○	—	—
○	○	○	○	○	—	○	○	○	○	○	○

Power Clamp Nano

NANO 纳米型热缩机，适用于小刀具的简易热缩机

Simple shrink fit machine for small tools.



气冷 (选配)
使用压缩空气冷却，
无需考虑刀具的外形，
小型刀具安装和
调整非常安全。

Air cooling (optional)
Cooling by compressed air,
regardless of contour and
safest handling for small
tool holders



止动盘
Stop disc



用于夹持刀柄的支撑盘
Chuck support for
tool holders with
bajonet clamping

长度设定 (可选)
水平长度设定单元
精度: 0.05mm

Length presetting (optional)
Horizontal length presetting unit
Tolerance 0,05 mm

NANO 纳米型热缩机 POWER CLAMP NANO

NANO 纳米型热缩机

- 功率: 13 kW
- 主电源: 3 x 400 – 480 V, 16A
- 刀具: 柄径为 $\varnothing 3 - \varnothing 16$ mm 的硬质合金和高速钢刀具
- 卧式结构易于操作

Power Clamp Nano

- Power: 13 kW
- Mains voltage: 3 x 400 – 480 V, 16 A
- Tools: solid carbide and HSS from $\varnothing 3 - 16$ mm
- Easy tool handling by horizontal shrinking

技术参数/Technical details

- 主电源/Mains voltage	3 x 400 – 480 Volt, 16 Ampere, 13 kW
- 刀具/Tools	硬质合金和高速钢/solid carbide and HSS
- 刀具柄径/Tool diameter	3–16 mm
- 最长刀具总长度/ Maximum Length of shrink fit chuck with tool	230 mm
- 尺寸 长x宽x高/Dimensions WxDxH	715x600x630 mm
- 重量/Weight	75 kg
- 订货号/Order No.	PC106-I04-C00-EU* 老订货号为: 80.160.00.3

附件/Accessories

订货号/Order No.

- Nano 纳米型热缩机用刀柄支撑盘/ Chuck support for Power Clamp Nano	参见第 51 页/see page 51
- Nano 纳米型热缩机用空气冷却装置/ Power Clamp Nano Air Cooling	80.164.00
- 适用于夹持孔径为 $\varnothing 3 - 12$ mm 的迷你型刀柄的冷却喷嘴/Cooling nozzle for Mini Shrink $\varnothing 3 - 12$ mm	80.164.02
- 长度设定单元/Length presetting	80.165.00.3
- Nano 纳米型热缩机的校准转换套/Calibration adapter Nano	80.165.01
- 长度设定用的刀具夹/Clips for tools for length presetting	
- $\varnothing 3$ mm	80.166.03
- $\varnothing 4$ mm	80.166.04
- $\varnothing 5$ mm	80.166.05
- $\varnothing 6$ mm	80.166.06
- $\varnothing 8$ mm	80.166.08
- $\varnothing 10$ mm	80.166.10
- $\varnothing 12$ mm	80.166.12
- 包含底座的刀具夹套装/Set of clips incl. plate	80.166.00



长度设定的校准转换套 (可选)

适用于测量设备的预设

Calibration adapter for length presetting (optional)

For resetting of the measuring device



刀具夹 (可选)

用于安全并精确地夹持高品质硬质合金刀具——特别适合小直径刀具

Clips for tools (optional)

For safest and precise handling of high quality carbide tools - especially for smaller diameters

*该设备的订货号和上述的设备配置相匹配。如果您需要不同的设备配置, 请联系客服人员以获得正确的订货号。
This order number matches the machine configuration as above. In case you like a different configuration, please contact your HAIMER representative for the right order number.

Power Clamp Smart

智能型热缩机——不带冷却系统的入门级热缩机
Entry-level shrink fit machine without cooling.



基本系列热缩机/POWER CLAMP BASIC LINE 智能型热缩/POWER CLAMP SMART

智能型热缩机

- 标准线圈
- 单支撑座型
- 没有冷却系统
- 含一个支撑座
- 含一个支撑盘
- 功率: 10 KW
- 主电源: 3 x 400 – 480 V, 16A
- 刀具: 柄径 Ø3 – Ø16 mm 的硬质合金和高速钢

Power Clamp Smart

- With standard coil
- Single chuck version
- Without cooling
- With 1 base holder
- With 1 chuck support
- Power: 10 kW
- Mains voltage: 3 x 400 – 480 V, 16 A
- Tools: solid carbide and HSS from Ø 3 – 16 mm

技术参数/Technical details

- 主电源/Mains voltage	3 x 400–480 V, 16 A, 10 kW
- 刀具/Tools	硬质合金和高速钢/solid carbide and HSS
- 刀具柄径/Tool diameter	3 – 16 mm
- 最长刀柄长度/Maximum length of shrink fit chuck	300 mm
- 尺寸 长x宽x高/Dimensions WxDxH	650 x 900 x 600 mm
- 重量/Weight	45 kg
- 订货号/Order No.	PC104-I01-C00-EU* 老订货号为: 80.143.00.3

附件/Accessories

订货号/Order No.

- 单支撑盘/ Chuck support for single-chuck system	参见第 61 页/see page 61
--	----------------------

Power Clamp Basic

基本型热缩机——不带冷却系统的入门级热缩机
Entry-level shrink fit machine without cooling.



基本系列热缩机/POWER CLAMP BASIC LINE 基本型热缩机/POWER CLAMP BASIC

基本型热缩机

- 标准线圈
- 单支撑座型
- 没有冷却系统
- 含一个支撑座
- 含一个支撑盘
- 功率: 10 KW
- 主电源: 3 x 400 – 480 V, 16A
- 刀具: 柄径 Ø3 – Ø32 mm 的硬质合金和高速钢

Power Clamp Basic

- With standard coil
- Single chuck version
- Without cooling
- With 1 base holder
- With 1 chuck support
- Power: 10 kW
- Mains voltage: 3 x 400 – 480 V, 16 A
- Tools: solid carbide and HSS from Ø 3 – 32 mm

技术参数/Technical details

- 主电源/Mains voltage	3 x 400–480 V, 16 A, 10 kW
- 刀具/Tools	硬质合金和高速钢/solid carbide and HSS
- 刀具柄径/Tool diameter	3 – 32 mm
- 最长刀柄长度/Maximum length of shrink fit chuck	350 mm
- 尺寸 长x宽x高/Dimensions WxDxH	650 x 900 x 600 mm
- 重量/Weight	45 kg
- 订货号/Order No.	PC105-I01-C00-EU*老订货号为: 80.150.00.3

附件/Accessories

订货号/Order No.

- 单支撑盘/ Chuck support for single-chuck system	参见第 61 页/see page 61
--	----------------------

增强系列热缩机/Power Clamp Profi Line: 模块化系统/The modular system

一步步递进式的热缩科技

基本设备可以连接上两块不同的背板和工作台面。可旋转的刀柄支撑盘可以根据需要订购。

Step by Step more shrink fit technology

Basic unit can be combined with two rear walls and two base plates. The chuck support for the rotary table will be supplied as requested.

附件/Accessories

- 冷却系统升级套装/
Speed-Cooler Upgrade Kit
带背板和 5 个冷却套的冷却机系统/
Speed-Cooler with rear wall incl. 5 cooling bodies
订货号/Order No. 80.115.00

- 旋转支撑盘升级套装 (= 舒适型热缩机)/Rotary table
Upgrade Kit(= Power Clamp Comfort)
带储物盒和三个旋转支撑座的台面/
Base plate with rotary table for 3 chucks
incl. craning boxes
订货号/Order No. 80.116.00

- 测量系统升级套装/Preset Upgrade Kit
含 2 个精密支撑盘, 储物盒, 带高度尺的测量台面/
Measuring plate, height gage,
2 precision base holder incl. craning boxes
订货号/Order No. 80.117.00

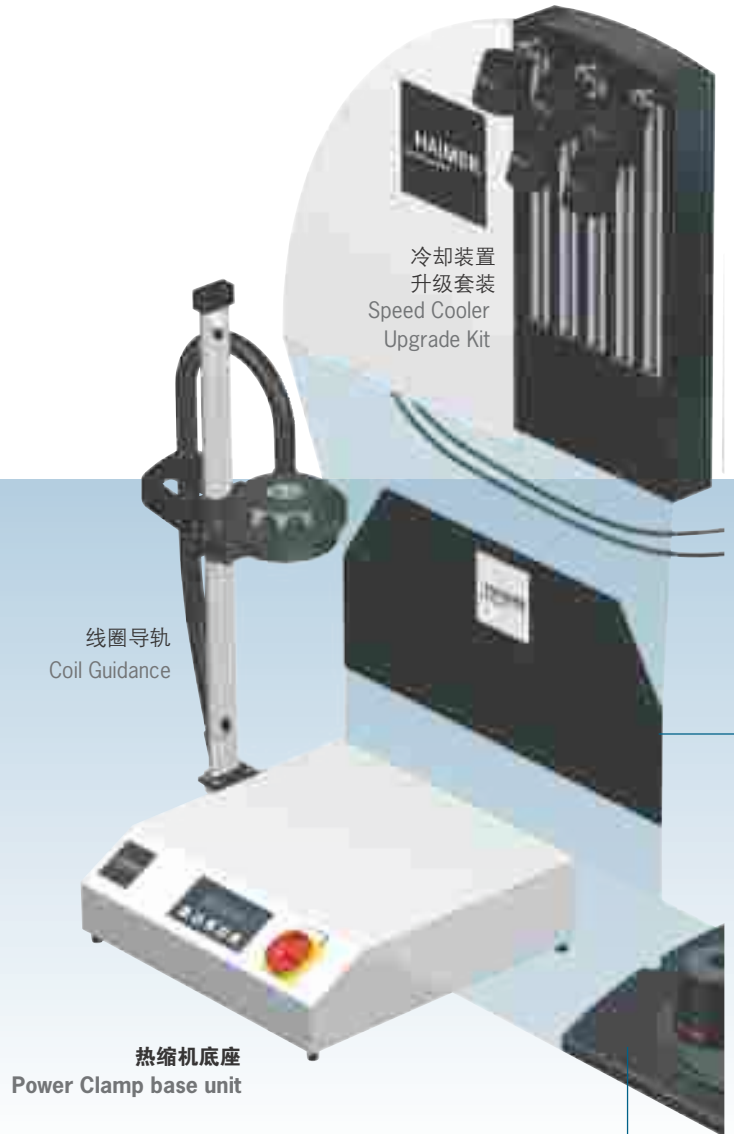

带旋转支座, 带储物盒, 能储放刀具的铝制台面
Base plate Standard made of aluminum with rotary table,
integrated tool tray and craning boxes

增强系列热缩机 / POWER CLAMP PROFI LINE

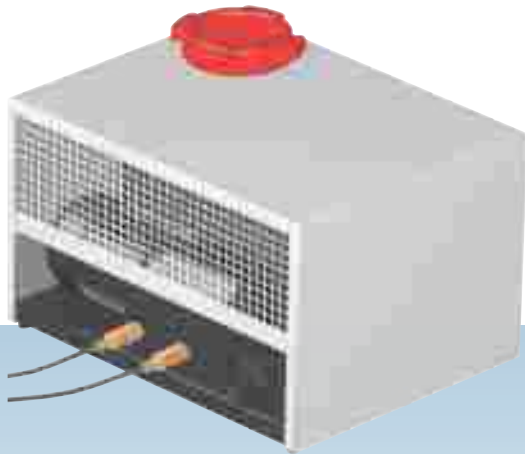

经济型背板
Rear wall Economic



刀具预调升级套装
Preset Upgrade Kit

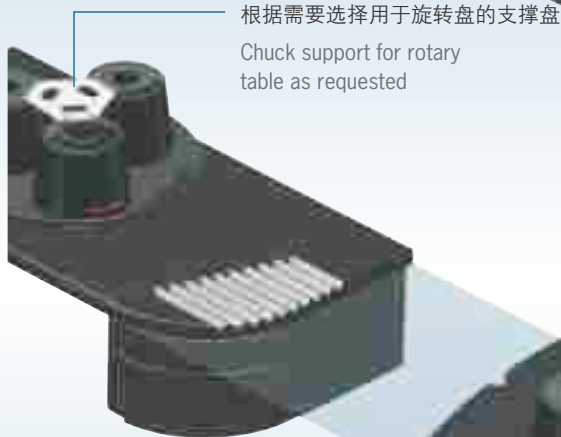

根据需要选择用于旋转盘的支撑盘
Chuck support for rotary table as requested

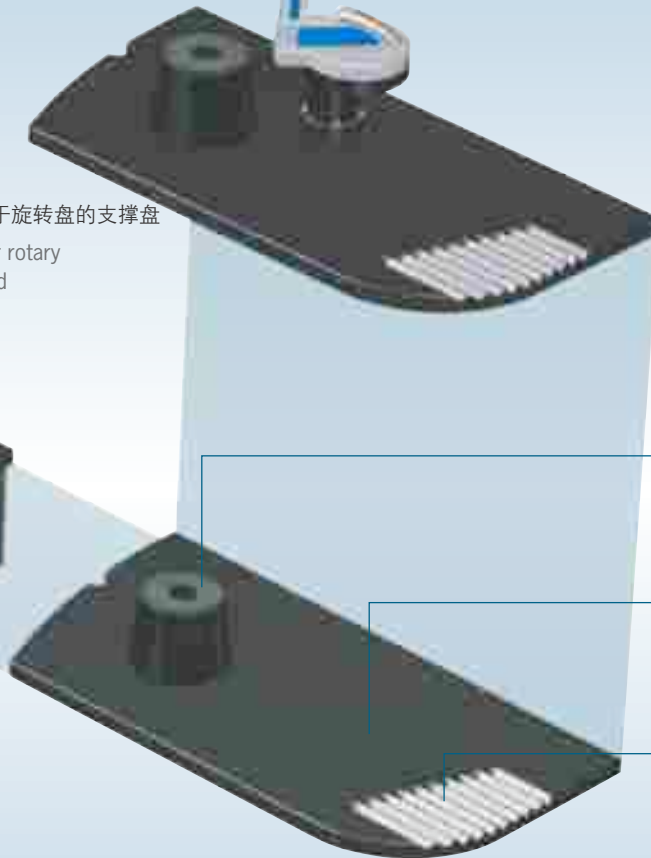

单刀柄支撑座系统
Base holder/Chuck support for single-chuck system

经济型和经济增强型用，带刀具储放盘的台面
Base plate Economic and Economic Plus with integrated tool tray

刀具储放盘
Tool tray for storage of tools

增强系列热缩机

Power Clamp Profi Line Program

从一个有效的配置的基本配置的机型开始 — 有力的补充：面向未来

现代热缩技术的开端：成本非常低的先进的线圈技术。因此问题不在于：是否应该投资在热缩技术上？而是“什么时候我将要投资在热缩技术上”。现在是时候投资在这个未来技术上了。

我们模块化系统提供了理想的启动方案。

A most useful start-up program – effective supplement: Tomorrow's technology.

A start into modern shrink fit technology: State of the art coil technology at low costs. The question is not “Should I invest in shrink fit technology” but rather “When will I invest in shrink fit technology”. It is now time to invest in the technology of the future.

Our modular system offers the ideal start-up solution.



NG 经济型热缩机不带冷却，不带旋转盘，带刀具储放盘

Power Clamp Economic NG without cooling, without rotary table, with integrated tool tray

增强系列热缩机 / POWER CLAMP PROFILINE

技术参数 / Technical details

- 舒适型的底座 / Basic unit Comfort	3 x 400–480 Volt, 16 A, 13 kW
- 最大的热缩刀柄的长度 (可根据需求加长) / Maximum length of shrink fit chuck (longer chucks upon request)	510 mm
- 尺寸 长x宽x高 / Dimensions WxDxH	840 x 600 x 970 mm
- 重量 / Weight	70 kg
- 冷却单元 / Speed-Cooler unit	230 Volt / 50 Hz, 1 kW
- 尺寸 / Dimensions	565 x 450 x 400 mm
- 重量 / Weight	45 kg



NG 经济增强型热缩机

含冷却系统，不含旋转支撑座，含单支撑座和刀具储放盘。

Power Clamp Economic Plus NG

with cooling, without rotary table, incl. 1 base holder and 1 chuck support, with integrated tool tray



NG 舒适型热缩机

含冷却系统，旋转支撑座，刀具储放盘和储物盒

Power Clamp Comfort NG

with cooling, rotary table, 1 chuck support, integrated tool tray and craning boxes



NG 强力型热缩机

- 加热时的功率：20 kW
- 可装拆柄径为 3 – 50 mm 的刀具
- 适合装拆硬质合金和高速钢刀具
- 可选择大的线圈 Ø40 – 50 mm (选选项)
- 含旋转支撑座
- 含刀具储放盘
- 含储物盒

**Power Clamp Profi Plus NG
High powered shrink fit machine**

- Heating power 20 kW
- For shrinking of tools from Ø 3–50 mm
- For HSS- and solid carbide tools
- Big coil for Ø 40–50 mm (optional)
- Incl. rotary table and chuck support
- Incl. tool tray
- With craning boxes for accessories

增强系列热缩机/POWER CLAMP PROFI LINE 翰默新一代热缩机/HAIMER POWER CLAMP NEW GENERATION

1 单手操作

- 线圈定位和加热仅需一只手即可完成

Single hand operation

- Positioning of coil and starting of shrink process with one hand

2 适用于快速冷却的冷却套

- 刀柄保持干燥
- 不会生锈
- 加热部分被覆盖
- 不会触及加热部分

Cooling bodies for rapid cooling

- Chucks remain dry
- No rust
- Hot spots always covered, no danger of injury
- Hot parts need not to be taken into the hand

3 旋转盘

- 工作迅速且有效
- 加热和冷却可同时在 3 个工作位置开展
- 节约时间

The turning table

- Work fast and efficient
- Heating and cooling at the same time on 3 stations
- No idle periods



支撑盘
Chuck support

4 三支撑盘

- 适合各种的锥度形式
- 不同锥度的支撑盘可以任意组合

Chuck support for 3 chucks

- For all actual tapers
- Also different tapers combined possible

7 显示屏

- 人性化操作面板
- 清晰、紧凑且容易操作

The display

- User-friendly operating panel
- Clear, compact and easy to handle



图片显示的是 NG 舒适型热缩机、附件及系统工具车
Picture shows Power Clamp Comfort NG with accessories and system cart

5 刀具储放盘

- 适合储放刀具
- 集成在底板上

The tool tray

- For laying down cutting tools
- Integrated in base plate

6 储物盒

- 适合存放附件
- 方便拿取

The craning boxes

- For accessories
- Everything close at hand

8 系统工具车

- 布局合理且符合人体工程学的工具车

The system cart

- For a clearly arranged and ergonomic work place

9 抽屉

- 适合各种附件的插件
- 各种附件各司其位

The drawer

- Profiled inserts for accessories
- Everything in its place

**增强系列热缩机/POWER CLAMP PROFI LINE
翰默新一代热缩机/HAIMER POWER CLAMP NEW GENERATION**



安全、干燥、快速的冷却

- 高效率: 在一支刀柄冷却的同时可以进行另一支刀柄的加热
- 水套冷却
- 接触式冷却, 提高冷却效果
- 整体冷却, 不会引起金属材料变形

Safe, dry, fast cooling

- Efficient: Shrink one holder while cooling another
- Water-cooled cooling bodies
- Concentrated cooling efficiency due to contact cooling
- Even cooling: No material deformation

智能线圈专利技术

(发明专利号码: CN 101189915 B*)

线圈可以根据刀柄自行调整高度和直径, 因此只有夹持刀具的区域被加热, 而其他位置不会, 加热和冷却更迅速。

Intelligent patented coil technology:

The coil adjusts itself to the chuck in length and diameter. Therefore only the shrinking area of the chuck will be warmed – nothing else. Shrinking and cooling will be much faster.



更有效, 更灵活, 操作更简单

- 线圈根据刀柄自行调整
- 由于线圈高度可以调整, 磁场分布完美
- 由于线圈高度可以调整, 热量分布更佳
- 加热后刀柄的温度更低
- 缩短加热时间
- 缩短冷却时间
- 操作简单
- 不需要止动盘
- 适合T型槽铣刀
- 适合超短刀柄
- 适合特殊形状的刀柄。

Even more efficiency, more flexibility, easier handling.

- Coil adjusts itself to the chuck
- Perfect magnetic flow due to length adjustment of the coil
- Optimal heat distribution due to length adjustment of the coil
- Lower chuck warming
- Shorter shrinking time
- Shorter cooling time
- Simple operation
- Contact disks are no longer necessary
- Suitable for T-shaped groove milling cutters
- Suitable for ultra-short chucks
- Suitable for special shape

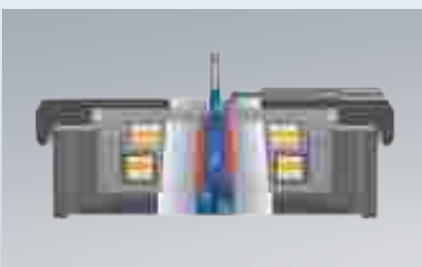

小直径刀具
Small tool



大直径刀具
Big tool

* 如需更多关于翰默专利的信息, 请联系翰默(上海)贸易有限责任公司。

Power Clamp Economic/ Power Clamp Economic NG

经济型热缩机/NG 经济型热缩机

入门级的不带冷却系统的增强系列热缩机

Profi Line entry-level shrink fit machine without cooling.



经济型热缩机/Power Clamp Economic

NG 经济型热缩机/Power Clamp Economic NG

**增强系列热缩机/POWER CLAMP PROFILINE
经济型热缩机/POWER CLAMP ECONOMIC
NG 经济型热缩机/POWER CLAMP ECONOMIC NG**

经济型热缩机

- 标准线圈
- 单支撑座型
- 没有冷却系统
- 含一个支撑座
- 含一个支撑盘
- 功率: 13 KW
- 主电源: 3 x 400 – 480 V, 16 A
- 刀具: 柄径为 Ø 3 – Ø 32 mm 的硬质合金和高速钢

Power Clamp Economic

- With standard coil
- Single chuck version
- Without cooling
- With 1 base holder
- With 1 chuck support
- Power: 13 kW
- Mains voltage: 3 x 400 – 480 V, 16 A
- Tools: solid carbide and HSS from Ø 3 – 32 mm

NG 经济型热缩机

- 智能 NG 线圈
- 单支撑座型
- 没有冷却系统
- 含一个支撑座
- 含一个支撑盘
- 功率: 13 KW
- 主电源: 3x400 – 480 V, 16 A
- 刀具: 柄径为 Ø 3 – Ø 32 mm 的硬质合金和高速钢

Power Clamp Economic NG

- With intelligent NG coil
- Single chuck version
- Without cooling
- With 1 base holder
- With 1 chuck support
- Power: 13 kW
- Mains voltage: 3 x 400 – 480 V, 16 A
- Tools: solid carbide and HSS from Ø 3 – 32 mm

技术参数/Technical details

- 主电源/Mains voltage	3 x 400 – 480 Volt, 16 Ampere, 13 kW
- 刀具/Tools	硬质合金和高速钢/solid carbide and HSS
- 刀具柄径/Tool diameter	3 – 32 mm
- 最长刀柄长度/ Maximum Length of shrink fit chuck	经济型热缩机//Economic: 510 mm/ NG 经济型热缩机/Economic NG: 570 mm
- 尺寸 长x宽x高/Dimensions WxDxH	840 x 600 x 970 mm
- 重量/Weight	60 kg
- Power Clamp Economic/经济型热缩机的订货号/Order No.	PC101-I01-C00-EU* 老订货号为: 80.110.00.3
- Power Clamp Economic NG/NG经济型热缩机的订货号/Order No.	PC101-I21-C00-EU* 老订货号为: 80.110.00NG.3

附件/Accessories

订货号/Order No.

- 储物盒/Cranning boxes	80.134.00NG
- 单支撑盘/Chuck support for single-chuck system	参见第 61 页/see page 61

*该设备的订货号和上述的设备配置相匹配。如果您需要不同的设备配置, 请联系翰默人员以获得正确的订货号。
This order number matches the machine configuration as above. In case you like a different configuration, please contact your HAIMER representative for the right order number.

Power Clamp Economic Plus/ Power Clamp Economic Plus NG

经济增强型热缩机/NG经济增强型热缩机
带冷却系统的高级的增强系列热缩机

Advanced Profi Line shrink fit machine with cooling.



NG 经济增强型热缩机/Power Clamp Economic Plus NG



经济增强型热缩机/Power Clamp Economic Plus

增强系列热缩机/POWER CLAMP PROFILINE
经济增强型热缩机/POWER CLAMP ECONOMIC PLUS
NG经济增强型热缩机/POWER CLAMP ECONOMIC PLUS NG

经济增强型热缩机

- 标准线圈
- 单支撑座型
- 带接触式冷却系统
- 含一个支撑座
- 含一个支撑盘
- 含冷却控制器
- 功率: 13 KW
- 主电源: 3 x 400 – 480 V, 16 A
- 刀具: 柄径为 Ø 3 – Ø 32mm 的硬质合金和高速钢刀具

Power Clamp Economic Plus

- With standard coil
- Single chuck version
- With integrated contact cooling
- With 1 base holder
- With 1 chuck support
- Incl. Cooling Manager
- Power: 13 kW
- Mains voltage: 3 x 400 – 480 V, 16 A
- Tools: solid carbide and HSS from Ø 3 – 32 mm

NG 经济增强型热缩机

可以升级到 HD 重型线圈以加热柄径至 Ø 50 mm 的重型热缩刀柄 (选配)

- 智能 NG 线圈
- 单支撑座
- 带接触式冷却
- 含一个支撑座
- 含一个支撑盘
- 含冷却控制器
- 功率: 13 KW
- 主电源: 3x400 – 480 V, 16 A
- 刀具: 柄径为 Ø 3 – Ø 32mm 的硬质合金和高速钢刀具

Power Clamp Economic Plus NG

Upgrade possible with HD coil for shrinking of Heavy Duty Shrink Chucks up to Ø 50 mm (on option)

- With intelligent NG coil
- Single chuck version
- With integrated contact cooling
- With 1 base holder
- With 1 chuck support
- Incl. Cooling Manager
- Power: 13 kW
- Mains voltage: 3 x 400 – 480 V, 16 A
- Tools: solid carbide and HSS from Ø 3 – 32 mm

技术参数/Technical details

- 主电源/Mains voltage	3 x 400 – 480 Volt, 16 Ampere, 13 kW
- 刀具/Tools	硬质合金和高速钢/solid carbide and HSS
- 刀具柄径/Tool diameter	3 – 32 mm
- 最长刀柄长度/ Maximum Length of shrink fit chuck	经济增强型热缩机/Economic Plus: 510 mm/ NG 经济增强型热缩机/Economic Plus NG: 570 mm
- 尺寸 长x宽x高/Dimensions WxDxH	840 x 600 x 970 mm
- 重量/Weight	110 kg
- Power Clamp Economic Plus/经济增强型热缩机订货号/Order No.	PC102-I01-C10-EU* 老订货号为: 80.110.01.3
- Power Clamp Economic Plus NG/NG 经济增强型热缩机订货号/Order No.	PC102-I21-C10-EU* 老订货号为: 80.110.01NG.3

附件/Accessories

订货号/Order No.

- 储物盒/Cranning boxes	80.134.00NG
- 单支撑盘/Chuck support for single-chuck system	参见第 61 页/See page 61
- NG 经济增强型热缩机升级用13KW HD 重型线圈套装/ Upgrade Kit 13 kW HD coil for Economic Plus NG	80.151.30.10

*该设备的订货号和上述的设备配置相匹配。如果您需要不同的设备配置, 请联系翰默人员以获得正确的订货号。
 This order number matches the machine configuration as above. In case you like a different configuration, please contact your HAIMER representative for the right order number.

Power Clamp Economic Plus Special Edition

特殊配置经济增强型热缩机

带冷却系统的高级增强系列热缩机

Special designed advanced shrink fit machine with cooling.



增强系列热缩/POWER CLAMP PROFI LINE 特殊配置经济增强型热缩机/POWER CLAMP ECONOMIC PLUS SPECIAL EDITION

特殊配置经济增强型热缩机

- 标准线圈
- 单支撑座型
- 带接触式冷却系统
- 含一个支撑座
- 含一个支撑盘
- 含冷却控制器
- 功率: 13 KW
- 主电源: 3 x 400 – 480 V, 16 A
- 刀具: 柄径为 $\varnothing 3 - \varnothing 32\text{mm}$ 的硬质合金和高速钢
刀具
- 特殊配置, 无法升级

Power Clamp Economic Plus Special Edition

- With standard coil
- Single chuck version
- With integrated contact cooling
- With 1 base holder
- With 1 chuck support
- Incl. Cooling Manager
- Power: 13 kW
- Mains voltage: 3x400–480V, 16A
- Tools: solid carbide and HSS from $\varnothing 3-32\text{ mm}$
- Special Edition machine, not available for upgrade

技术参数/Technical details

- 主电源/Mains voltage	3 x 400 – 480 V, 16 A, 13 kW
- 刀具/Tools	硬质合金和高速钢/solid carbide and HSS
- 刀具柄径/Tool diameter	3 – 32 mm
- 最长刀柄长度/Maximum length of shrink fit chuck	510 mm
- 尺寸 长x宽x高/Dimensions WxDxH	840 x 600 x 970 mm
- 重量/Weight	132 kg
- 特殊配置经济增强型热缩机 订货号/ Economic Plus Special Edition Order No.	PC102-I01-C10-EU-SE* 老订货号为80.110.01SE.3

附件/Accessories

订货号/Order No.

- 单支撑盘/ Chuck support for single-chuck system	参见第 61 页/see page 61
--	----------------------

*该设备的订货号和上述的设备配置相匹配。如果您需要不同的设备配置, 请联系翰默人员以获得正确的订货号。
This order number matches the machine configuration as above. In case you like a different configuration, please contact your HAIMER representative for the right order number.

Power Clamp Comfort/ Power Clamp Comfort NG

舒适型热缩机/NG 舒适型热缩机

带 3 工位和冷却系统的高性能增强系列热缩机

Profi Line high performance shrink fit machine for ambitious with 3 stations and cooling.



舒适型热缩机/Power Clamp Comfort

NG 舒适型热缩机/Power Clamp Comfort NG

**增强系列热缩机/POWER CLAMP PROFILINE
舒适型热缩机/POWER CLAMP COMFORT
NG 舒适型热缩机/POWER CLAMP COMFORT NG**

舒适型热缩机

- 标准线圈
- 三工位旋转盘
- 带接触式冷却
- 含冷却控制器
- 含一组用于旋转盘的支撑盘
- 不含储物盒
- 功率: 13 KW
- 主电源: 3 x 400 – 480 V, 16 A
- 刀具: 柄径为 Ø 3 – Ø 32mm 的硬质合金和高速钢刀具

Power Clamp Comfort

- With standard coil
- Rotary table with 3 stations
- With integrated contact cooling
- Incl. Cooling Manager
- With 1 chuck support for rotary table
- Without craning boxes
- Power: 13 kW
- Mains voltage: 3 x 400 – 480 V, 16 A
- Tools: solid carbide and HSS from Ø 3 – 32 mm

NG 舒适型热缩机

可以升级到 HD 线圈以加热柄径至 Ø 50mm 的重型热缩刀柄 (选配)

- 智能 NG 线圈
- 三工位旋转盘
- 带接触式冷却
- 含冷却控制器
- 含一组用于旋转盘的支撑盘
- 含储物盒
- 功率: 13 KW
- 主电源: 3 x 400 – 480 V, 16 A
- 刀具: 柄径为 Ø 3 – Ø 32mm 的硬质合金和高速钢刀具

Power Clamp Comfort NG

Upgrade possible with HD coil for shrinking of Heavy Duty Shrink Chucks up to Ø 50 mm (on option)

- With intelligent NG coil
- Rotary table with 3 stations
- With integrated contact cooling
- Incl. Cooling Manager
- With 1 chuck support for rotary table
- With craning boxes
- Power: 13 kW
- Mains voltage: 3 x 400 – 480 V, 16 A
- Tools: solid carbide and HSS from Ø 3 – 32 mm

技术参数/Technical details

- 主电源/Mains voltage	3 x 400 – 480 Volt, 16 Ampere, 13 kW
- 刀具/Tools	硬质合金和高速钢/solid carbide and HSS
- 刀具柄径/Tool diameter	3 – 32 mm
- 最长刀柄长度/ Maximum Length of shrink fit chuck	舒适型热缩机/Power Clamp Comfort: 510 mm/ NG 舒适型热缩机/Comfort NG: 570 mm
- 尺寸 长x宽x高/Dimensions WxDxH	840 x 600 x 970 mm
- 重量/Weight	115 kg
- Power Clamp Comfort/舒适型热缩机订货号/Order No.	PC100-I01-C10-EU* 老订货号为: 80.100.00.3
- Power Clamp Comfort NG/NG 舒适型热缩机订货号/Order No.	PC100-I21-C10-EU* 老订货号为: 80.100.00NG.3

附件/Accessories

订货号/Order No.

- 储物盒/Craning boxes for Power Clamp Comfort	80.134.00NG
- 旋转支撑盘/Chuck support for rotary table	参见第 65 页/See page 65
- NG 舒适型热缩机升级用13KW HD 重型线圈套装/ Upgrade Kit 13 kW HD coil for Power Clamp Comfort NG	80.151.30.10

*该设备的订货号和上述的设备配置相匹配。如果您需要不同的设备配置, 请联系客服人员以获得正确的订货号。
This order number matches the machine configuration as above. In case you like a different configuration, please contact your HAIMER representative for the right order number.

Power Clamp Profi Plus NG

NG 强力型热缩机

带冷却系统的专业级高性能热缩机，适用于最大柄径为 \varnothing 50mm的刃具

High performance shrink fit machine for professionals up to \varnothing 50 mm and with cooling.



增强系列热缩机/POWER CLAMP PROFILINE NG 强力型热缩机/POWER CLAMP PROFI PLUS NG

NG 强力型热缩机

- 智能 NG 线圈
- 三工位旋转盘
- 带接触式冷却
- 含冷却控制器
- 可以选择加热柄径从 $\varnothing 40 - \varnothing 50$ mm 刀具的第二个线圈
- 含一组用于旋转盘的支撑盘
- 功率: 20 KW
- 含储物盒
- 主电源: 3 x 400 – 480 V, 32 A
- 刀具: 柄径为 $\varnothing 3 - \varnothing 50$ mm 的硬质合金和高速钢刀具

Power Clamp Profi Plus NG

- With intelligent NG coil
- Rotary table with 3 stations
- With integrated contact cooling
- Incl. Cooling Manager
- Optional with second coil for $\varnothing 40 - 50$ mm
- With 1 chuck support for rotary table
- Power: 20 kW
- with craning boxes
- Mains voltage: 3 x 400 – 480 V, 32 A
- Tools: solid carbide and HSS from $\varnothing 3 - 50$ mm

技术参数/Technical details

- 主电源/Mains voltage	3 x 400 – 480 Volt, 32 Ampere, 20 kW
- 刀具/Tools	硬质合金和高速钢/solid carbide and HSS
- 刀具柄径/Tool diameter	3 – 32 mm
- 最长刀柄长度/ Maximum Length of shrink fit chuck	570 mm
- 尺寸 长x宽x高/Dimensions WxDxH	1000 x 600 x 970 mm
- 重量/Weight	128 kg
- Power Clamp Profi Plus NG/NG 强力型热缩机订货号/Order No.	PC120-I21-C10-EU* 老订货号为: 80.100.10NG.3

附件/Accessories

订货号/Order No.

- 旋转支撑盘/Chuck support for rotary table	参见第 65 页/see page 65
- 升级至 20KW HD 重型线圈的套装/Upgrade Kit 20KW HD coil	80.151.40

*该设备的订货号和上述的设备配置相匹配。如果您需要不同的设备配置, 请联系翰默人员以获得正确的订货号。
This order number matches the machine configuration as above. In case you like a different configuration, please contact your HAIMER representative for the right order number.

Power Clamp Preset NG

NG 测量型热缩机

带刀长预调装置和冷却系统的专业级高性能热缩机

High performance shrink fit machine for professionals with length presetting and cooling.



增强系列热缩机/POWER CLAMP PROFILINE NG 测量型热缩机/POWER CLAMP PRESET NG

NG 测量型热缩机

- 可以升级到 HD 重型线圈以加热夹持直径至 \varnothing 50 mm 的重型热缩刀柄 (选配)
- 带测量尺
 - 智能 NG 线圈
 - 单支撑座型
 - 带接触式冷却
 - 含冷却控制器
 - 含 2 个精密支撑座
 - 含 2 个精密支撑盘
 - 功率: 13 KW
 - 含储物盒
 - 主电源: 3 x 400 – 480 V, 16 A
 - 刀具: 柄径为 \varnothing 3 – \varnothing 32mm 的硬质合金和高速钢刀具

Power Clamp Preset NG

- Upgrade possible with HD coil for shrinking of Heavy Duty Shrink Chucks up to \varnothing 50 mm (on option)
- With vertical stop for length presetting
 - With intelligent NG coil
 - Single chuck version
 - With integrated contact cooling
 - Incl. Cooling Manager
 - With 2 precision base holders
 - With 2 precision chuck supports
 - Power: 13 kW
 - with craning boxes
 - Mains voltage: 3 x 400 – 480 V, 16 A
 - Tools: solid carbide and HSS from \varnothing 3 – 32 mm

技术参数/Technical details

- 主电源/Mains voltage	3 x 400 – 480 Volt, 16 Ampere, 13 kW
- 刀具/Tools	硬质合金和高速钢/solid carbide and HSS
- 刀具柄径/Tool diameter	3 – 32 mm
- 最长刀柄长度/ Maximum Length of shrink fit chuck	570 mm
- 尺寸 长x宽x高/Dimensions WxDxH	840 x 600 x 1110 mm
- 重量/Weight	110 kg
- Power Clamp Preset NG/NG 测量型热缩机订货号/Order No.	PC103-I21-C10-EU* 老订货号为: 80.130.00NG.3

附件/Accessories

订货号/Order No.

- 精密支撑盘/Precision chuck support	参见第 63 页/see page 63
- 升级至 13KW HD 重型线圈套装/Upgrade Kit 13 kW HD coil	80.151.30.10

*该设备的订货号和上述的设备配置相匹配。如果您需要不同的设备配置, 请联系翰默人员以获得正确的订货号。
This order number matches the machine configuration as above. In case you like a different configuration, please contact your HAIMER representative for the right order number.

Power Clamp Premium Plus

超级增强型热缩机

拥有很高工艺可靠性的高端热缩机

High-end shrink fit machine for absolute process reliability.



增强系列热缩机/POWER CLAMP PROFILINE 超级增强型热缩机/POWER CLAMP PREMIUM PLUS

拥有很高工艺可靠性的高端热缩机，有两个独立的电气单元和线圈

- 含智能 VS 32m 线圈和 20 KW 线圈
- 含温度控制的智能冷却系统
- 冷却结束后，冷却套自动升起（温度 - 时间可以控制）
- 含六个接触式的冷却套
- 冷却套沿线性导轨滑动
- 不会损坏切削刀具的刃口
- 含冷却控制器
- 含两个带高度止动块的长度预调单元
- 含 2 个精密支撑座和 2 个精密支撑盘
- 含三个集成式抽屉
- 功率：33 KW
- 主电源：3 x 400 V, 63 A
- 刀具：柄径为 $\varnothing 3 - \varnothing 50\text{mm}$ 的硬质合金和高速钢
刀具

High-end shrink fit machine with two separate electronic units and two coils

- With intelligent motor coil VS32m and 20kW coil
- TME Intelligent Cooling System with temperature control
- Automatic move-up of the cooling bodies after the termination of the cooling process (temperature-time controlled)
- Integrated contact cooling with six cooling bodies
- Linear guided cooling bodies
- No damage at the edges of the cutting tool
- Incl. Cooling Manager
- Two length presetting units with height stop
- Incl. 2 precision base holders and 2 precision chuck supports
- 3 integrated drawers
- Power: 33kW
- Mains voltage: 3x400V, 63A
- Tools: solid carbide and HSS from $\varnothing 3-50\text{ mm}$

技术参数/Technical details

– 主电源/Mains voltage	3 x 400 Volt, 63 Ampere, 33 kW
– 压缩空气/Compressed Air	6 bar
– 刀具/Tools	硬质合金和高速钢/solid carbide and HSS
– 刀具柄径/Tool diameter	3 – 50 mm
– 最长刀柄长度/ Maximum Length of shrink fit chuck	535 mm
– 尺寸 长x宽x高/Dimensions WxDxH	1601 x 890 x 2300 mm
– 重量/Weight	760 kg
– Power Clamp Premium Plus/超级增强型热缩机订货号/Order No.	PC107-I41-I03-C11-EU* 老订货号为: 80.170.10.3

附件/Accessories

订货号/Order No.

– 精密支撑盘/Precision chuck support	参见第 63 页/see page 63
– 精密支撑座/Precision base holder for chuck support	80.131.01

*该设备的订货号和上述的设备配置相匹配。如果您需要不同的设备配置，请联系翰默人员以获得正确的订货号。
This order number matches the machine configuration as above. In case you like a different configuration, please contact your HAIMER representative for the right order number.



工业4.0纳米型NG热缩机
Power Clamp Nano NG i4.0



工业4.0气冷经济型/舒适型热缩机
Power Clamp Air i4.0 Eco/Comfort



工业4.0舒适型热缩机
Power Clamp Comfort i4.0



工业4.0测量型热缩机
Power Clamp Preset i4.0

POWER CLAMP i4.0 Line:

工业4.0级的热缩机技术—准备就绪

Shrinking Technology Industry 4.0-ready

通过新的工业4.0级的热缩机
翰默HAIMER正在制定刀具
和机床数字化通信与连接的
新标准。

With the new Power Clamp i4.0 series
HAIMER is setting new standards regard-
ing digital connectivity and communi-
cation of tools and machines in the
world of manufacturing.



工业4.0超级型热缩机
Power Clamp Premium i4.0



工业4.0全能型热缩机
Power Clamp Sprint i4.0

工业 4.0 级翰默热缩机的亮点 Power Clamp i4.0 Line Highlights

通过新的工业 4.0 级的热缩机，翰默HAIMER正在制定刀具和机床数字化通信与连接的新标准。

所有工业 4.0 级翰默热缩机都具备以下特征：

- 7 英寸的触摸屏和全新的直观的软件，简单易用
- 网络兼容和工业 4.0 - 随时准备在信息系统内沟通
- 扫码枪从刀柄上的二维码中读取热缩参数 (选配)
- 用于柄径为 3 - 32 毫米的刀具的专利 NG 线圈 (发明专利号码：CN 101189915 B*)

With the new Power Clamp i4.0 series HAIMER is setting new standards regarding digital connectivity and communication of tools and machines in the world of manufacturing.

All Power Clamp i4.0 shrink fit machines are equipped with the following features:

- 7"-Touch-Display and new intuitive software for simplified usability
- Network-compatible and industry 4.0-ready for communication in the shopfloor
- Scanner to readout shrinking parameters from Data-Matrix codes (optional)
- Patented NG-coil for tool diameters from 3 – 32 mm



触控显示屏

- 7 英寸的触摸屏和全新的直观的软件
- 用户友好的界面
- 说明功能
- 清晰的符号，大字体
- 稳定的彩色显示屏
- 防水、耐刮擦、耐冲击

Touch-Display

- 7" Touch-Display and new intuitive software
- User-friendly Interface
- Illustrated functions
- Clear symbols, large font
- Robust color display
- Water, scratch and impact resistant



手持式扫码枪

扫码枪从刀柄上的二维码中读取热缩参数，实现简单的自动读取热缩参数 (选配)

Hand scanner

Scanner to readout shrinking parameters from Data-Matrix codes for easiest automatic shrinking (optional)

工业 4.0 级的冷却系统 Cooling i4.0



工业 4.0 超级型热缩机

带冷却状态显示功能的接触式冷却系统

- 实现快速冷却的冷却水套
- 自动显示当前的冷却状态，简易快速安全的冷却系统
- 冷却时间记录：大约 30 秒
- 刀柄保持干燥，不易生锈
- 刀柄的冷却过程非常温和和均匀；跳动精度保持不变
- 加热部分被覆盖，无烫伤危险

POWER CLAMP PREMIUM i4.0

Contact cooling with signaling of the right cooling station

- Cooling body for rapid cooling
- Automatic signaling of the right cooling station for easy, fast and safe cooling
- Cooling in record time: approx. 30 s
- Tool holders remain dry, no build-up of rust
- Gentle handling of chuck by even cooling; runout accuracy is maintained
- Hot points are always covered, no risk of injury

工业 4.0 全能型热缩机

冷却时无需考虑刀具的外部轮廓

- 适用于各种刀具的冷却，不需要再选择冷却水套
- 安全、流畅、清洁的冷却流程，无污垢、无水渍
- 具有温度控制的智能冷却系统

POWER CLAMP SPRINT i4.0

Cooling regardless of the outside contour

- One fits all – cooling for all kind of cutting tools, no more selecting of cooling bodies
- Save, smooth and clean cooling without dirt and water residue
- Intelligent cooling system with temperature control

Power Clamp Nano NG i4.0

工业 4.0 纳米型 NG 热缩机

适用于小型刀具及热缩筒夹的卧式热缩机

Horizontal i4.0 shrink fit machine for tool holders and shrink fit collets.



自动线圈
Intelligent
motor coil

气冷装置
Air cooling



针对不同接口的刀柄
的支撑盘

Chuck support for
tool holders with
bajonet clamping

手持式扫码枪
Hand-held scanner

长度预调装置(选配)
水平方向的长度预调单元, 预调精度
为0.05mm

Length presetting (optional)
Horizontal length presetting unit
Tolerance 0,05 mm



刀具夹(选配)
安全, 精密的夹持高品质的硬质合金
刀具-尤其适合超小直径的刀具

Clips for tools (optional)
For safest and precise handling of high
quality carbide tools – especially with
smaller diameters



长度预调专用校正转换套(选配)
用于重置测量装置

Calibration adapter for length presetting
(optional)
For resetting the measuring device

工业 4.0 系列热缩机/POWER CLAMP i4.0 LINE 工业 4.0 纳米型 NG 热缩/POWER CLAMP NANO NG i4.0

工业 4.0 纳米型 NG 热缩机是专门为高速主轴使用的小直径热缩刀柄以及热缩筒夹设计的热缩机。最大的热缩刀柄接口为 SK40/HSK-A63。

- 卧式热缩, 简易装夹
- 配置自动 NG 线圈
- 用于从刀柄上的二维码中读取热缩参数的扫码枪
- 气冷, 冷却范围 \varnothing 3 – 32 mm
- 7 英寸的触摸屏和全新的直观的软件
- 扫码枪连接, 工业 4.0 就绪
- 功率: 13 kW
- 主电源: 3 x 400-480V, 16A
- 刀具: \varnothing 3-32 mm 的硬质合金及高速钢

Power Clamp Nano NG i4.0 is especially suitable for small tool holders in high frequency spindles, for shrink fit collets and for shrink fit chucks up to SK40/HSK-A63.

- Easy tool handling by horizontal shrinking
- With intelligent motor coil
- With scanner to readout shrinking parameters from tool holders (Data-Matrix code)
- With air cooling for tools from \varnothing 3–32 mm
- With 7"-Touch-Display and new intuitive software
- Industry 4.0-ready due to scanner connection
- Power: 13 kW
- Mains voltage: 3x400–480V, 16A
- Tools: solid carbide and HSS from \varnothing 3–32 mm

技术参数/Technical details

- 主电源/Mains voltage	3 x 400 – 480 V, 16 A, 13 kW
- 压缩空气/Compressed Air	6 bar
- 刀具/Tools	硬质合金和高速钢/solid carbide and HSS
- 刀具柄径/Tool diameter	3 – 32 mm
- 最长刀具总长度/Maximum length of shrink fit chuck with tool	250 mm
- 尺寸 长x宽x高/Dimensions WxDxH	800 x 860 x 670 mm
- 重量/Weight	94 kg
- 工业 4.0 纳米型 NG 热缩机 订货号/ Power Clamp Nano NG i4.0 Order No.	PC406-I42-C20-EU* 老订货号为 80.160.20NGM.3

附件/Accessories

订货号/Order No.

- 工业 4.0 纳米型 NG 热缩机用刀柄支撑盘/ Chuck support for Power Clamp Nano NG i4.0	参见第 61 页/see page 61
- 长度预调单元/Length presetting	80.165.20.3
- Nano 校准转换套/Calibration adapter Nano	80.165.01
- 刀具夹套装/Set of clips incl. plate	80.166.00
- 系统工具车/System Cart	80.124.00.8
- 系统工具车用插件/Insert for System Cart	80.124.07

应用举例/Application example



热缩筒夹

工业 4.0 纳米型 NG 热缩机可以完美地加热及冷却热缩筒夹。

Shrink Fit Collets

Power Clamp Nano NG i4.0 is perfectly suitable for process reliable shrinking and cooling of shrink fit collets.

* 该设备的订货号和上述的设备配置相匹配。如果您需要不同的设备配置, 请联系客服人员以获得正确的订货号。
This order number matches the machine configuration as above. In case you like a different configuration, please contact your HAIMER representative for the right order number.

Power Clamp Air i4.0 Eco

工业 4.0 气冷经济型热缩机

适用于热缩刀柄及热缩筒夹的工业 4.0 气冷经济型热缩机

Economic i4.0 shrink fit machine for tool holders and shrink fit collets.



工业 4.0 系列热缩机/POWER CLAMP i4.0 LINE

工业4.0气冷经济型热缩机/POWER CLAMP AIR i4.0 ECO

工业4.0气冷经济型热缩机是一款配置了可冷却各种刃具(硬质合金及高速钢)的独立气冷装置的高性能的热缩机。

它可以完美地加热及冷却各种类型的热缩刀柄及热缩筒夹。

通过压缩空气对各种类型的刀柄进行流畅及干净的冷却-不残留任何污垢及冷却液。

- 带温度控制的独立气冷装置
- 带触摸释放功能的冷却罩
- 自动结束的冷却进程
- 7英寸的触摸屏和全新的直观的软件
- 扫码枪连接,工业4.0就绪
- 智能NG线圈
- 单支撑座型
- 含两个精密支撑座及两个精密支撑盘
- 带储物盒
- 含一个冷却控制器

Power Clamp Air i4.0 Eco is a high performance shrink fit machine with integrated cooling for all tools (solid carbide and HSS).

It is perfectly suitable for process reliable shrinking and cooling of shrink fit collets and tool holders.

Smooth and clean cooling of all kinds of tool holders by air – without dirt and water residue.

- Contour independent air cooling with temperature control
- Pneumatic brake of cooling hood with release-by-touch
- Cooling process finishes automatically
- With 7"-Touch-Display and new intuitive software
- Industry 4.0-ready due to scanner connection
- With intelligent NG coil
- Single chuck version
- With 2 precision base holders and 2 precision chuck supports
- With craning boxes
- Incl. Cooling Manager

技术参数/Technical details

- 主电源/Mains voltage	3 x 400 – 480 V, 16 A, 13 kW
- 压缩空气/Compressed Air	6 bar
- 刃具/Tools	硬质合金和高速钢/solid carbide and HSS
- 刃具柄径/Tool diameter	3 – 32 mm
- 可加热的最长热缩刀柄的长度/Maximum length of shrink fit chuck (shrinking)	570 mm
- 可冷却的最长刀具的总长度/Maximum total length of assembled tool (cooling)	250 mm
- 尺寸 长x宽x高/Dimensions WxDxH	880 x 750 x 1100 mm
- 重量/Weight	105 kg
- 工业 4.0 气冷经济型热缩机 订货号/ Power Clamp Air i4.0 Eco Order No.	PC409-I21-C21-EU*老订货号为80.180.40NG.3

附件/Accessories

订货号/Order No.

- 用于从二维码中读取热缩参数的扫码枪/ Scanner to readout shrinking parameters from Data-Matrix codes	80.185.01
- 精密支撑盘/Precision chuck support	参见第 63 页/See page 63
- 智能自动线圈/Intelligent motor coil	80.101.03NG
- 长度预调装置/Length presetting	80.188.40
- 废气收集装置/Auxiliary Fume Extraction Unit	80.101.02NG.01
- 系统工具车/System Cart	80.124.00.8
- 系统工具车用插件/Insert for System Cart	80.124.06

应用举例/Application example



热缩筒夹

工业4.0气冷经济型热缩机可以完美地加热及冷却热缩筒夹

Shrink Fit Collets

Power Clamp Air i4.0 Eco is perfectly suitable for process reliable shrinking and cooling of shrink fit collets

*该设备的订货号和上述的设备配置相匹配。如果您需要不同的设备配置,请联系客服人员以获得正确的订货号。
This order number matches the machine configuration as above. In case you like a different configuration, please contact your HAIMER representative for the right order number.

Power Clamp Air i4.0 Comfort

工业 4.0 气冷舒适型热缩机

适用于热缩刀柄及热缩筒夹的工业 4.0 气冷舒适型热缩机

Comfort i4.0 shrink fit machine for tool holders and shrink fit collets.



图片显示的是带长度预调装置(选配)的PC409-I41-C21-EU热缩机
Picture shows PC409-I41-C21-EU with length presetting (optional)

工业 4.0 系列热缩机/POWER CLAMP i4.0 LINE 工业 4.0 气冷舒适型热缩机/POWER CLAMP AIR i4.0 COMFORT

工业 4.0 气冷舒适型热缩机是一款配置了可冷却各种刀具(硬质合金及高速钢)的独立气冷装置的高性能的热缩机。

它可以完美加热及冷却所有类型的热缩刀柄及热缩筒夹。

通过压缩空气对各种类型的刀柄进行顺畅及干净的冷却-不残留任何污垢及冷却液。

- 带温度控制的独立气冷装置
- 带触摸释放功能的冷却罩
- 自动结束冷却进程
- 7英寸的触摸屏和全新的直观的软件
- 扫码枪连接,工业4.0就绪
- 用于从刀柄上的二维码中读取热缩参数的扫码枪
- 自动NG线圈
- 单支撑座型
- 含两个精密支撑座及两个精密支撑盘
- 含储物盒
- 含冷却控制器

Power Clamp Air i4.0 Comfort is a high performance shrink fit machine with integrated cooling for all tools (solid carbide and HSS).

It is perfectly suitable for process reliable shrinking and cooling of shrink fit collets and tool holders.

Smooth and clean cooling of all kinds of tool holders by air – without dirt and water residue.

- Contour independent air cooling with temperature control
- Pneumatic brake of cooling hood with release-by-touch
- Cooling process finishes automatically
- With 7"-Touch-Display and new intuitive software
- Industry 4.0-ready due to scanner connection
- With scanner to readout shrinking parameters from tool holders (Data-Matrix code)
- With intelligent motor coil
- Single chuck version
- With 2 precision base holders and 2 precision chuck supports
- With craning boxes
- Incl. Cooling Manager

技术参数/Technical details

- 主电源/Mains voltage	3 x 400 – 480 V, 16 A, 13 kW
- 压缩空气/Compressed Air	6 bar
- 刀具/Tools	硬质合金和高速钢/solid carbide and HSS
- 刀具柄径/Tool diameter	3 – 32 mm
- 可加热的最长热缩刀柄的长度/Maximum length of shrink fit chuck (shrinking)	570 mm
- 可冷却的最长刀具的总长度/Maximum total length of assembled tool (cooling)	260 mm
- 尺寸 长x宽x高/Dimensions WxDxH	880 x 750 x 1100 mm
- 重量/Weight	105 kg
- 工业 4.0 气冷舒适型热缩机 订货号/Power Clamp Air i4.0 Comfort Order No.	PC409-I41-C21-EU*

附件/Accessories

订货号/Order No.

- 长度预调装置/Length presetting	80.188.40
- 精密支撑盘/Precision chuck support	参见第 63 页/see page 63
- 废气收集装置/Auxiliary Fume Extraction Unit	80.101.02NG.01
- 系统工具车/System Cart	80.124.00.8
- 系统工具车用插件/Insert for System Cart	80.124.06

应用举例/Application example



热缩筒夹

工业 4.0 气冷舒适型热缩机可以完美地加热及冷却热缩筒夹。

Shrink Fit Collets

Power Clamp Air i4.0 Comfort is perfectly suitable for process reliable shrinking and cooling of shrink fit collets.

* 该设备的订货号和上述的设备配置相匹配。如果您需要不同的设备配置, 请联系翰默人员以获得正确的订货号。
This order number matches the machine configuration as above. In case you like a different configuration, please contact your HAIMER representative for the right order number.

Power Clamp Comfort i4.0

工业 4.0 舒适型热缩机

助您实现雄心壮志的工业 4.0 级热缩机

i4.0 shrink fit machine for ambitious.



工业 4.0 系列热缩机 / POWER CLAMP i4.0 LINE

工业 4.0 舒适型热缩机 / POWER CLAMP COMFORT i4.0

通过新的工业 4.0 级的热缩机，翰默 HAIMER 正在制定热缩技术的数字化连接和通信的新标准。

7 英寸的触摸屏和全新的直观的软件，简单易用。

可以升级至 HD 重型线圈，用于夹持柄径达 Ø 50mm 的重型热缩刀柄。（选配）

- 网络兼容及工业 4.0 化
- 7 英寸的触摸屏和全新的直观的软件
- 带智能 NG 线圈
- 3 工位旋转盘
- 带接触式冷却系统
- 含冷却控制器
- 带一个用于旋转盘的支撑盘
- 带储物盒
- 功率：13KW
- 主电压：3×400-480V,16A
- 刀具：柄径为 Ø 3 – Ø 32mm 的硬质合金和高速钢刀具
- 通过扫码枪读取二维码，简单的实现自动读取热缩参数（选配）
- TME 温控系统（选配）

With the new Power Clamp i4.0 series HAIMER is setting new standards regarding digital connectivity and communication in the world of shrink technology.

A 7"-Touch-Display and a new intuitive software provide simplified usability.

Upgrade possible with HD coil for shrinking of Heavy Duty Shrink Chucks up to Ø 50 mm (optional)

- Network-compatible and industry 4.0-ready
- With 7"-Touch-Display and new intuitive software
- With intelligent NG coil
- Rotary table with 3 stations
- With integrated contact cooling
- Incl. Cooling Manager
- With 1 chuck support for rotary table
- With craning boxes
- Power: 13 kW
- Mains voltage: 3 x 400 – 480 V, 16 A
- Tools: solid carbide and HSS from Ø 3 – 32 mm
- Scanner to readout shrinking parameters from Data-Matrix codes for easiest automatic shrinking (optional)
- TME Cooling System (optional)

技术参数/Technical details

- 主电源/Mains voltage	3 x 400 – 480 Volt, 16 Ampere, 13 kW
- 刀具/Tools	硬质合金和高速钢/solid carbide and HSS
- 刀具柄径/Tool diameter	3 – 32 mm
- 最长刀柄长度/Maximum Length of shrink fit chuck	570 mm
- 尺寸 长x宽x高/Dimensions WxDxH	850 x 660 x 970 mm
- 重量/Weight	115 kg
- Power Clamp Comfort i4.0/工业 4.0 舒适型热缩机订货号/Order No.	PC400-I21-C10-EU* 老订货号为：80.100.20NG.3

附件/Accessories

订货号/Order No.

- 扫码枪从二维码读取热缩参数/ Scanner to readout shrinking parameters from Data-Matrix codes	80.185.01
- 用于旋转盘的支撑盘/Chuck support for rotary table	参见第 65 页/See page 65
- 为工业 4.0 舒适型热缩机将线圈升级为 13KW 重型线圈套装/ Upgrade Kit 13 kW HD coil for Power Clamp Comfort i4.0	80.151.30.10
- 废气收集装置/Auxiliary Fume Extraction Unit	80.101.02NG.01
- 系统工具车/System Cart	80.124.00.8
- 用于 13KW 热缩机的 TME 温控系统（选配）/ TME Cooling System for 13 kW machines (optional)	按需提供/on request

*该设备的订货号和上述的设备配置相匹配。如果您需要不同的设备配置，请联系翰默人员以获得正确的订货号。
This order number matches the machine configuration as above. In case you like a different configuration, please contact your HAIMER representative for the right order number.

Power Clamp Preset i4.0

工业 4.0 测量型热缩机

带强大的刀长预调装置的工业 4.0 级热缩机

i4.0 shrink fit machine for ambitious with length presetting.



工业 4.0 系列热缩机 / POWER CLAMP i4.0 LINE

工业 4.0 测量型热缩机 / POWER CLAMP PRESET i4.0

通过新的工业 4.0 级的热缩机，翰默 HAIMER 正在制定热缩技术的数字化连接和通信的新标准。

7 英寸的触摸屏和全新的直观的软件，简单易用。

可以升级至 HD 重型线圈，用于夹持柄径达 Ø 50mm 的重型热缩刀柄。（选配）

- 网络兼容及工业 4.0 化
- 7 英寸的触摸屏和全新的直观的软件
- 带立式高度尺
- 带智能 NG 线圈
- 单支撑座型
- 带接触式冷却系统
- 含冷却控制器
- 含 2 个精密支撑座和 2 个精密支撑盘
- 带储物盒
- 功率：13KW
- 主电压：3×400-480V,16A
- 刀具：柄径从 Ø 3-Ø 32mm 的硬质合金和高速钢刀具
- 扫码枪通过刀柄上的二维码读取热缩参数，实现简单的自动读取热缩参数（选配）
- TME 温控系统（选配）

With the new Power Clamp i4.0 series HAIMER is setting new standards regarding digital connectivity and communication in the world of shrink technology.

A 7"-Touch-Display and a new intuitive software provide simplified usability.

Upgrade possible with HD coil for shrinking of Heavy Duty Shrink Chucks up to Ø 50 mm (optional)

- Network-compatible and industry 4.0-ready
- With 7"-Touch-Display and new intuitive software
- With vertical stop for length presetting
- With intelligent NG coil
- Single chuck version
- With integrated contact cooling
- Incl. Cooling Manager
- With 2 precision base holders and 2 precision chuck supports
- With craning boxes
- Power: 13 kW
- Mains voltage: 3 x 400 – 480 V, 16 A
- Tools: solid carbide and HSS from Ø 3 – 32 mm
- Scanner to readout shrinking parameters from Data-Matrix codes for easiest automatic shrinking (optional)
- TME Cooling System (optional)

技术参数/Technical details

- 主电源/Mains voltage	3 x 400 – 480 Volt, 16 Ampere, 13 kW
- 刀具/Tools	硬质合金和高速钢/solid carbide and HSS
- 刀具柄径/Tool diameter	3 – 32 mm
- 最长刀柄长度/Maximum Length of shrink fit chuck	570 mm
- 尺寸 长x宽x高/Dimensions WxDxH	850 x 660 x 970 mm
- 重量/Weight	115 kg
- Power Clamp Preset i4.0/工业 4.0 测量型热缩机订货号/Order No.	PC403-I21-C10-EU* 老订货号为：80.130.20NG.3

附件/Accessories

订货号/Order No.

- 扫码枪从二维码读取热缩参数/ Scanner to readout shrinking parameters from Data-Matrix codes	80.185.01
- 精密支撑盘/Precision chuck support	参见第 63 页/See page 63
- 为工业 4.0 测量型热缩机将线圈升级为 13KW 重型线圈套装/ Upgrade Kit 13 kW HD coil for Power Clamp Preset i4.0	80.151.30.10
- 废气收集装置/Auxiliary Fume Extraction Unit	80.101.02NG.01
- 系统工具车/System Cart	80.124.00.8
- 用于 13KW 热缩机的 TME 温控系统（选配）/ TME Cooling System for 13 kW machines (optional)	按需提供/on request

*该设备的订货号和上述的设备配置相匹配。如果您需要不同的设备配置，请联系翰默人员以获得正确的订货号。
This order number matches the machine configuration as above. In case you like a different configuration, please contact your HAIMER representative for the right order number.

Power Clamp Premium i4.0

工业 4.0 超级型热缩机

符合人体工程学的高端热缩机

Ergonomic i4.0 high-end shrink station.



图片所示为配置长度预调单元及扫码枪（选配）的 PC407-I22-C11-EU 机型
Picture shows PC407-I22-C11-EU with length presetting and scanner (optional)

工业4.0系列热缩机/POWER CLAMP i4.0 LINE

工业4.0超级型热缩机/POWER CLAMP PREMIUM i4.0

新设计的符合人体工程学的热缩机，适用于各种刀具（硬质合金和高速钢），配置了最多可以同时使用5个冷却工位的接触式冷却装置。它制定了热缩技术数字化通信以及连接的新标准。

- 7英寸的触摸屏和全新的直观的软件
- 网络兼容及工业4.0化
- 功率：13 KW
- 主电压：3 × 400 – 480 V, 16A
- 刀具：柄径为 Ø 3 – Ø 32mm的硬质合金和高速钢刀具
- 配置 NG 线圈
- 带温控的智能冷却系统
- 带接触式冷却的5个冷却套
- 线性导向的冷却套机构，可以自动显示当前的冷却状态，简易、快速、安全的冷却系统
- 不会破坏切削刀刃
- 包含一个快速冷却机及冷却控制器
- 包含2个精密支撑座及2个精密支撑盘
- 含一个集成在工具柜上的抽屉
- 扫码枪通过刀柄上的二维码读取热缩参数，实现简单的自动读取热缩参数（选配）
- 长度预调单元（选配）

Ergonomic high-end shrink station in new, premium quality industry design with integrated contact cooling for all cutting tools (solid carbide and HSS) and for perfect handling and simultaneous cool-down at max. five cooling stations. setting new standards regarding digital connectivity and communication in the world of shrink technology.

- With 7"-Touch-Display and new intuitive software
- Network-compatible and industry 4.0-ready
- Power: 13 kW
- Mains voltage: 3 x 400 – 480 V, 16 A
- Tools: solid carbide and HSS from Ø 3 – 32 mm
- With NG coil
- TME Intelligent Cooling System with temperature control
- Integrated contact cooling with five cooling bodies
- Linear guided cooling bodies with automatic signaling of the right cooling station for easy, fast and safe cooling
- No damage at the edges of the cutting tool
- Incl. Speed Cooler and Cooling Manager
- Incl. 2 precision base holders and 2 precision chuck supports
- Integrated drawer in base cabinet
- Scanner to readout shrinking parameters from Data-Matrix codes for easiest automatic shrinking (optional)
- Length presetting (optional)

技术参数/Technical details

- 主电源/Mains voltage	3 x 400 – 480 Volt, 16 Ampere, 13 kW
- 刀具/Tools	硬质合金和高速钢/solid carbide and HSS
- 刀具柄径/Tool diameter	3 – 32 mm
- 最长刀柄长度/Maximum Length of shrink fit chuck	535 mm
- 尺寸 长x宽x高/Dimensions WxDxH	1340 x 914 x 1816 mm
- 重量/Weight	535kg 包含工具柜/incl. base cabinet
- Power Clamp Premium i4.0/工业4.0超级型热缩机订货号/Order No.	PC407-I22-C11-EU* 老订货号为：80.180.00NG

附件/Accessories

订货号/Order No.

- 扫码枪从刀柄上的二维码读取热缩参数/ Scanner to readout shrinking parameters from Data-Matrix codes	80.185.00
- 工业4.0级超级型热缩机升级用13 KW HD 重型线圈套装/ Upgrade Kit 13 kW HD coil for Power Clamp Premium i4.0	80.151.30.10S
- 精密支撑盘/Precision chuck support	参见第63页/See page 63
- 精密支撑座/Precision base holder for chuck support	80.131.01
- 长度预调单元/Length presetting	80.188.00
- 废气吸收装置/Auxiliary Fume Extraction Unit	80.101.02NG.03

*该设备的订货号和上述的设备配置相匹配。如果您需要不同的设备配置，请联系客服人员以获得正确的订货号。
This order number matches the machine configuration as above. In case you like a different configuration, please contact your HAIMER representative for the right order number.

Power Clamp Sprint i4.0

工业 4.0 全能型热缩机

适用于冷却各种几何形状刀具的

符合人体工程学的工业 4.0 级热缩机

Ergonomic i4.0 shrink station for cooling of all geometries.



图片显示为配置长度预调单元及扫码枪（选配）的 PC408-I22-C21-EU 热缩机
Picture shows PC408-I22-C21-EU with length presetting and scanner (optional)

工业4.0系列热缩机/POWER CLAMP i4.0 LINE

工业4.0全能型热缩机/POWER CLAMP SPRINT i4.0

最新设计的符合人体工程学的高端热缩机，可以快速冷却所有种类的切削刀具（硬质合金和高速钢）以及热缩筒夹。

- 7英寸的触摸屏和全新的直观的软件
- 网络兼容及工业4.0化
- 功率：13 KW
- 主电压：3 x 400 – 480 V, 16A
- 刀具：柄径为 $\varnothing 3 - \varnothing 32$ mm的硬质合金和高速钢刀具
- 配置 NG 线圈
- 通过冷却装置的喷嘴喷出的气雾能够快速冷却及清洁各种类型的热缩刀柄及热缩筒夹。并且由于采用了气化喷雾的冷却方式，将不会有任何的污垢及水残留
- 温度控制优化，更安全的冷却
- 不会损坏切削刀具
- 包含 2 个精密支撑座及 2 个精密支撑盘
- 含一个集成在工具柜上的抽屉
- 扫码枪通过刀柄上的二维码读取热缩参数，实现简单的自动读取热缩参数（选配）
- 长度预调单元（选配）

Ergonomic shrink station in new, premium quality industry design with integrated cooling for all kind of cutting tools (solid carbide and HSS) and shrink fit collets in record time.

- With 7"-Touch-Display and new intuitive software
- Network-compatible and industry 4.0-ready
- Power: 13 kW
- Mains voltage: 3 x 400 – 480 V, 16 A
- Tools: solid carbide and HSS from $\varnothing 3 - 32$ mm
- With NG coil
- Smooth and clean cooling of all kind of shrink fit chucks and shrink fit collets regardless of the outside contour by air nozzles and drizzle – without dirt and water residue
- Temperature control for optimized and safe cooling
- No damage at the edges of the cutting tool
- Incl. 2 precision base holders and 2 precision chuck supports
- Integrated drawer in base cabinet
- Scanner to readout shrinking parameters from Data-Matrix codes for easiest automatic shrinking (optional)
- Length presetting (optional)

技术参数/Technical details

- 主电源/Mains voltage	3 x 400–480 Volt, 16 Ampere, 13 kW
- 压缩空气/Compressed Air	6 bar
- 刀具/Tools	硬质合金和高速钢/solid carbide and HSS
- 刀具柄径/Tool diameter	3 – 32 mm
- 最长刀柄长度/Maximum Length of shrink fit chuck	535 mm
- 尺寸 长x宽x高/Dimensions WxDxH	1340 x 962 x 2560 mm 工作时的最大高度/max. work height 1340 x 962 x 1960 mm 运输时的高度/transportation height
- 重量/Weight	550 kg 包含工具柜/incl. base cabinet
- Power Clamp Sprint i4.0 /工业4.0全能型热缩机订货号/Order No.	PC408-I22-C21-EU* 老订货号为：80.180.20NG

附件/Accessories

订货号/Order No.

- 扫码枪从刀柄的二维码上读取热缩参数/ Scanner to readout shrinking parameters from Data-Matrix codes	80.185.00
- 工业4.0级全能型热缩机升级用13 KW HD 重型线圈套装/ Upgrade Kit 13 kW HD coil for Power Clamp Sprint i4.0	80.151.30S
- 精密支撑盘/Precision chuck support	参见第 63 页/See page 63
- 精密支撑座/Precision base holder for chuck support	80.131.01
- 长度预调单元/Length presetting	80.188.00
- 废气回收装置/Auxiliary Fume Extraction Unit	80.101.02NG.03



热缩筒夹

工业4.0全能型热缩机可以完美地加热及冷却热缩筒夹。

Shrink Fit Collets

Power Clamp Sprint i4.0 is perfectly suitable for process reliable shrinking and cooling of shrink fit collets.

*该设备的订货号和上述的设备配置相匹配。如果您需要不同的设备配置，请联系客服人员以获得正确的订货号。
This order number matches the machine configuration as above. In case you like a different configuration, please contact your HAIMER representative for the right order number.

附件/Accessories



系统工具车抽屉插件

(不包含附件)

Drawer insert for system cart

(does not include accessories)

技术参数/Technical details

- 订货号/ Drawer Order No.	80.124.04
----------------------------	-----------



系统工具车

- 储放热缩机和附件
- 使工作环境整洁
- 高度符合人体工程学
- 方便取用
- 选项：可存储附件的抽屉插件

System cart

- Cart for shrinking machine and accessories
- For a clear and tidy work space
- Ergonomic work height
- Everything at hand
- Optional: Drawers with inserts to store accessories

技术参数/Technical details

- 系统工具车/System cart	
尺寸/Dimensions	1000 x 620 x 840 mm
订货号/Order No.	80.124.00.4



简易工具车/Cart for shrink fit machine

技术参数/Technical details

- 订货号/Cart Order No.	80.106.00.3
----------------------	-------------

支撑座
BASE HOLDER



适用于所有尺寸的刀柄支撑盘：
两种形式可供选择
To hold chuck supports of all sizes.
Available in two versions:

适用于智能型/基本型/经济型/经济增强型/特殊配置经济增强型热缩机的支撑座

Base holder for Power Clamp Smart/Basic/Economic/Economic Plus/Special Edition



适用于测量型/超级增强型/工业4.0测量型/工业4.0超级型/工业4.0全能型/工业4.0气冷经济型/工业4.0气冷舒适型热缩机的精密支撑座
为了达到最佳精度，精密支撑座的每个功能面都被精磨处理过

Precision base holder for Power Clamp Preset/Premium Plus/Air i4.0/Preset i4.0/Premium i4.0/Sprint i4.0

High precision version with fine machined functional surfaces for maximum precision at length presetting.

	订货号/Order No.
- 适用于智能型/基本型/经济型/经济增强型/特殊配置经济增强型热缩机的支撑座/ Base holder for Power Clamp Smart/Basic/Economic/Economic Plus/Special Edition	80.155.01
- 适用于测量型/超级增强型/工业4.0测量型/工业4.0超级型/工业4.0全能型/ 工业4.0气冷经济型/工业4.0气冷舒适型热缩机的精密支撑座 Precision base holder for Power Clamp Preset/Premium Plus/Air i4.0/Preset i4.0/Premium i4.0/Sprint i4.0	80.131.01

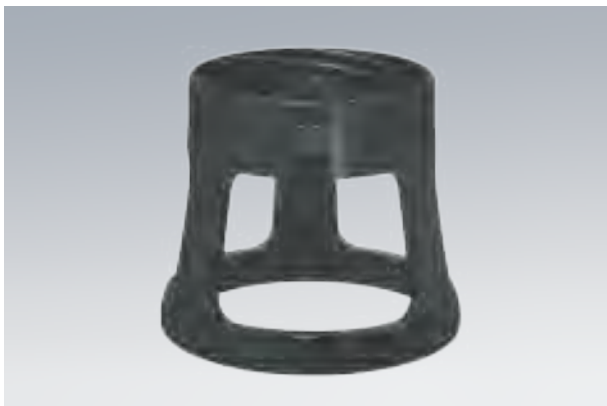

适用于翰默 ER 热缩筒夹的精密支撑座

为了达到最佳精度，精密支撑座的每个功能面都被精磨处理过。开放的底部设计便于调节刀具的长度

Precision base holder for HAIMER ER shrink fit collets.

High precision version with fine machined functional surfaces for maximum precision at length presetting. Open base design for optimal access to adjust the length.

适用于翰默 ER 热缩筒夹的精密支撑座

Precision base holder for HAIMER ER shrink fit collets

订货号/Order No.

– 适用于翰默 ER 热缩筒夹的精密支撑座
Precision base holder for HAIMER ER shrink fit collets

80.131.02

NANO 纳米型热缩机的支撑盘

CHUCK SUPPORT FOR POWER CLAMP NANO



NANO 纳米型卧式热缩机使用的支撑盘

适用于锥柄尺寸 SK30 – SK40, BT30 – BT40, JBS T15, HSK-25 – HSK-63, PSC40 – PSC63, ER11 – ER32

Chuck support for horizontal shrink fit machine

Power Clamp Nano.

Available in taper sizes SK30 – SK40, BT30 – BT40, JBS T15, HSK-25 – HSK-63, PSC40 – PSC63, ER11 – ER32

NANO 纳米型和工业4.0纳米型卧式热缩机使用的精密支撑盘

Precision chuck support for Power Clamp Nano/Nano NG i4.0

锥柄尺寸/For taper size	订货号/Order No.
– SK/BT 30, 拉钉标准DIN 69872/MAS403(也可用于面接触型刀柄) SK/BT30 with pull stud DIN 69872/MAS 403 (also for version with Face Contact)	80.162.30
– SK30/BT30, 不带拉钉, 带 M12螺纹孔(也可用于面接触型刀柄) SK30 without pull stud with thread M12 (also for version with Face Contact)	80.162.30.01
– SK40/BT40, 不带拉钉, 带M16螺纹孔(也可用于面接触型刀柄) SK40 without pull stud with thread M16 (also for version with Face Contact)	80.162.40.01
– SK40/BT40, 带DIN 69872标准的拉钉(也可用于面接触型刀柄) SK40 with pull stud DIN 69872 (also for version with Face Contact)	80.162.40.02
– SK/BT 40, 带ISO 7388-B标准的拉钉(也可用于面接触型刀柄) SK40 with pull stud ISO 7388-B (also for version with Face Contact)	80.162.40.04
– SK/BT 40, 带MAS 403标准的拉钉(也可用于面接触型刀柄) BT40 with pull stud MAS 403 (also for version with Face Contact)	80.162.40.06
– JBS T15, 带JBS R15-45标准的拉钉/JBS T15 with pull stud JBS R15-45	80.162.T15
– HSK-25	80.163.25
– HSK-32	80.163.32
– HSK-40	80.163.40
– HSK-50	80.163.50
– HSK-63	80.163.63
– PSC 40	80.167.C4
– PSC 50	80.167.C5
– PSC 63	80.167.C6
– ER11	80.168.ER11
– ER16	80.168.ER16
– ER20	80.168.ER20
– ER25	80.168.ER25
– ER32	80.168.ER32



适用于单支撑座的支撑盘

可适用于锥柄尺寸：SK30 – SK50, BT30 – BT50, HSK-25 – HSK-125, KM4X63*, KM4X100*, PSC 32 – PSC 80, Makino F63, Makino F80

Chuck support for single-chuck system.

Available in taper sizes SK30 – SK50, BT30 – BT50, HSK-25 – HSK-125, KM4X63*, KM4X100*, PSC 32 – PSC 80, HSK-F63 Makino, HSK-F80 Makino

适用于智能型/基本型/经济型/ NG 经济型/ 经济增强型/NG 经济增强型 / 特殊配置经济增强型热缩机的支撑盘
Precision chuck support for Power Clamp Smart, Basic, Economic/NG, Economic Plus/NG, Special Edition

锥柄尺寸/For taper size	订货号/Order No.
– SK/BT30用(也可用于面接触型刀柄/also for version with Face Contact)	80.112.30
– SK/BT40用(也可用于面接触型刀柄/also for version with Face Contact)	80.112.40
– SK/BT45用(也可用于面接触型刀柄/also for version with Face Contact)	80.112.45
– SK/BT50用(也可用于面接触型刀柄/also for version with Face Contact)	80.112.50
– HSK-25	80.113.25
– HSK-32	80.113.32
– HSK-40	80.113.40
– HSK-50/HSK-63F	80.113.50
– HSK-63/KM4X63*	80.113.63
– HSK-80	80.113.80
– HSK-100/KM4X100*	80.113.10
– HSK-125	80.113.125
– HSK-F63 Makino	80.113.F63M
– HSK-F80 Makino	80.113.F80M
– PSC 32	80.114.30
– PSC 40	80.114.40
– PSC 50	80.114.50
– PSC 63	80.114.60
– PSC 80	80.114.80
– KM63	80.114.KM63

精密支撑盘 PRECISION CHUCK SUPPORT



单刀柄用精密支撑盘

– 每个功能面都精磨处理

适用于锥度尺寸：SK30 – SK50, HSK-25 – HSK-125, KM4X63*, KM4X100*, PSC 32 – PSC 80, Makino F63, Makino F80

Precision chuck support for single-chuck system.

– Fine machined functional surfaces

Available in taper sizes SK30 – SK50, HSK-25 – HSK-125, KM4X63*, KM4X100*, PSC 32 – PSC 80, HSK-F63 Makino, HSK-F80 Makino

适用于NG 测量型/超级增强型/工业 4.0气冷经济型/工业 4.0气冷舒适型/工业 4.0 测量型/
工业 4.0 超级型/工业 4.0 全能型热缩机的精密支撑盘

Precision chuck support for Power Clamp Preset NG/Power Clamp Premium Plus/Power Clamp Air i4.0 Eco/
Comfort/Power Clamp Preset i4.0/Power Clamp Premium i4.0/Power Clamp Sprint i4.0

锥柄尺寸/For taper size	订货号/Order No.
– SK30	80.132.30
– SK40	80.132.40
– SK50	80.132.50
– HSK-25	80.133.25
– HSK-32	80.133.32
– HSK-40	80.133.40
– HSK-50	80.133.50
– HSK-63	80.133.63
– HSK-80	80.133.80
– HSK-100	80.133.10
– HSK-125	80.133.125
– PSC 32	80.134.30
– PSC 40	80.134.40
– PSC 50	80.134.50
– PSC 63	80.134.60
– PSC 80	80.134.80

超级增强型热缩机用精密支撑盘

PRECISION CHUCK SUPPORT FOR POWER CLAMP PREMIUM PLUS



超级增强型热缩机用精密支撑盘

- 每个功能面都精磨处理
- 含刀柄保护销

适用锥度尺寸：SK30 – SK50, BT30 – BT50, HSK-25 – HSK-125, HSK-F63M – HSK-F80M, PSC32 – PSC80

Precision chuck support for Power Clamp Premium Plus.

- Fine machined functional surfaces
- With pin for protection of the chuck

Available in taper sizes SK30 – SK50, BT30 – BT50, HSK-25 – HSK-125, HSK-F63 Makino, HSK-F80 Makino, PSC 32 – PSC 80

适用于超级增强型热缩机的精密支撑盘

Precision chuck support for Power Clamp Premium Plus

锥柄尺寸/For taper size	订货号/Order No.
- SK30	80.172.30
- SK40	80.172.40
- SK45	80.172.45
- SK50	80.172.50
- BT30	80.175.30
- BT40	80.175.40
- BT45	80.175.45
- BT50	80.175.50
- HSK-25	80.173.25
- HSK-32	80.173.32
- HSK-40	80.173.40
- HSK-50	80.173.50
- HSK-63	80.173.63
- HSK-80	80.173.80
- HSK-100	80.173.10
- HSK-125	80.173.125
- HSK-F63 Makino	80.173.F63M
- HSK-F80 Makino	80.173.F80M
- PSC 32	80.174.30
- PSC 40	80.174.40
- PSC 50	80.174.50
- PSC 63	80.174.60
- PSC 80	80.174.80

适用于旋转盘的支撑盘

CHUCK SUPPORT FOR ROTARY TABLE

**旋转支撑盘**

适合锥度尺寸: SK30 – SK50, BT30 – BT50,
HSK-25 – HSK-100, PSC32 – PSC80

Chuck support for rotary table.

Available in taper sizes SK30 – SK50,
BT30 – BT50, HSK-25 – HSK-100,
PSC 32 – PSC 80

支撑盘适用于: NG 强力型/舒适型/ NG 舒适型/工业 4.0 舒适型热缩机

Chuck support for Power Clamp Profi Plus/Profi Plus NG/Comfort/Comfort NG/Comfort i4.0

锥柄尺寸/For taper size	订货号/Order No.
– SK/BT30用(也可用于面接触型刀柄/also for version with Face Contact)	80.102.30
– SK/BT40用(也可用于面接触型刀柄/also for version with Face Contact)	80.102.40
– SK/BT45用(也可用于面接触型刀柄/also for version with Face Contact)	80.102.45
– SK/BT50用(也可用于面接触型刀柄/also for version with Face Contact)	80.102.50
– 任意尺寸/various sizes	80.103.00
– HSK-25	80.103.25
– HSK-32	80.103.32
– HSK-40	80.103.40
– HSK-50	80.103.50
– HSK-63	80.103.63
– HSK-80	80.103.80
– HSK-100	80.103.10
– PSC 32	80.104.30
– PSC 40	80.104.40
– PSC 50	80.104.50
– PSC 63	80.104.60
– PSC 80	80.104.80

ER 热缩筒夹用支撑盘

CHUCK SUPPORT FOR ER SHRINK FIT COLLETS



ER 热缩筒夹用，带长度调整的支撑盘

- 高精度夹持
- 含快速可重复调整长度的止动杆
- 利用止动螺钉和反面的螺母来调节
- 集成在支撑盘上，节省空间
- 只需旋转螺钉和螺母，操作简单
- 尤其适合于多轴机床，可保证姊妹刀具的长度一致性

Chuck support for ER shrink fit collets with integrated length presetting.

- Precise clamping of the collet
- Fast and repeatable length adjustment with stop pin
- Adjustment with set screw and counter nut
- Integrated in chuck support, thus very space-saving
- Easy handling by turning of set screw and counter nut
- Application suitable also at multi-spindle machines for repeatable length presetting of twin tools

锥柄尺寸/For taper size

订货号/Order No.

- ER11	80.135.11
- ER16	80.135.16
- ER20	80.135.20
- ER25	80.135.25
- ER32	80.135.32
- 适用于智能型/基本型/经济型/NG 经济型/经济增强型/ NG 经济增强型/特殊配置经济增强型热缩机的支撑座 Base holder for Power Clamp Smart/Basic/Economic/Economic Plus/Special Edition	80.155.01

适用于翰默 ER 热缩筒夹的精密支撑盘

CHUCK SUPPORT FOR HAIMER ER SHRINK FIT COLLETS



适用于翰默 ER 热缩筒夹的带内置式长度预调装置的精密支撑盘

- 轻轻的一拧，筒夹就固定在该夹具上了
- 筒夹不会移动，工艺稳定性高
- 带止动杆的长度预调装置，快速且重复精度高
- 内置于支撑座中，非常节约空间
- 利用定位螺钉和反面的螺母来调节
- 通过旋转螺钉和螺母操作，非常简便
- 尤其适用于多轴机床，可保证姊妹刀具的长度一致性

Chuck support for HAIMER ER shrink fit collets with integrated length presetting.

- Fixture of collet by screwing on chuck support.
- High process stability, no movement of collet possible
- Fast and repeatable length adjustment with stop pin
- Integrated in chuck support, thus very space-saving
- Adjustment with set screw and counter nut
- Easy handling by turning of set screw and counter nut
- Application suitable also at multi-spindle machines for repeatable length presetting of twin tools

锥柄尺寸/For taper size

订货号/Order No.

- ER11	80.137.ER11
- ER16	80.137.ER16
- ER20	80.137.ER20
- ER25	80.137.ER25
- ER32	80.137.ER32
- 适用于翰默 ER 热缩筒夹的精密支撑座 Precision base holder for HAIMER ER shrink fit collets	80.131.02

EASY SET 简易长度预调装置/SIMPLE PRESETTING

简单预调

- 快速简单地调节刀具的悬长
- 最大悬升长度: 150 mm
- 精度: ± 0.05 mm
- 适用于所有的热缩刀柄和热缩机 (火焰, 热风, 接触式, 感应式)
- 节省空间
- 性价比高
- 选配灵活
- 发货含: 3个止动片($\varnothing 3-12$, $\varnothing 12-20$, $\varnothing 16-25$ mm)
- 选项: $\varnothing 25-32$ mm

Simple presetting

- Quick and simple presetting of the protruding length of the tool
- Maximum protruding length: 150 mm
- Accuracy: ± 0.05 mm
- Suitable for all shrink fit chucks and machines (flame, hot air, contact, induction)
- Space saving
- Excellent relationship between price and efficiency
- Can be added at any time
- Included in delivery: 3 stop clips ($\varnothing 3-12$, $\varnothing 12-20$, $\varnothing 16-25$ mm),
 Optional: $\varnothing 25-32$ mm

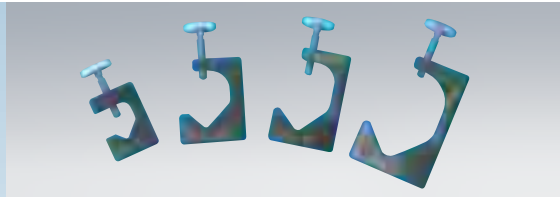

止动片/
Stop clips

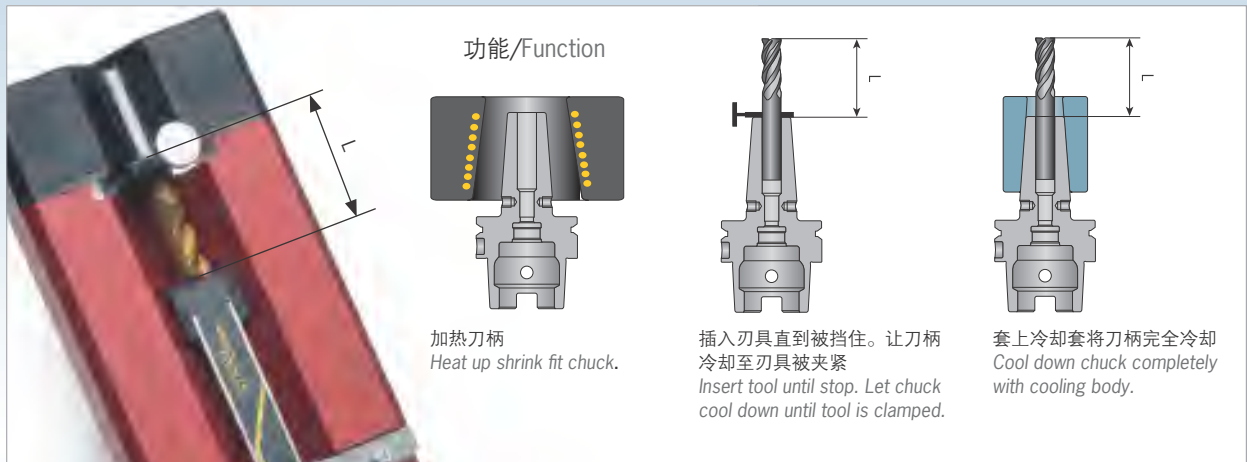

简易长度预调装置/Easy Set

订货号/Order No.

- 悬伸长度/100 mm protruding length	80.123.00
- 悬伸长度/150 mm protruding length	80.125.00
- $\varnothing 3-12$ mm止动片的夹持柄径/Stop clip for clamping $\varnothing 3-12$ mm	80.123.01
- $\varnothing 12-20$ mm止动片的夹持柄径/Stop clip for clamping $\varnothing 12-20$ mm	80.123.02
- $\varnothing 16-25$ mm止动片的夹持柄径/Stop clip for clamping $\varnothing 16-25$ mm	80.123.03
- $\varnothing 25-32$ mm止动片的夹持柄径/Stop clip for clamping $\varnothing 25-32$ mm	80.123.04

QUICK SET 快速长度预调装置/LENGTH PRESETTING

适用于无支撑螺钉的刀柄（例如：迷你型刀柄）的刀具长度预调

- 利用止动杆可以重复而快速的调节刀具长度
- 利用止动螺钉和反面的螺母来调节
- 内置于支撑盘中，节省空间
- 操作方便，只需调节螺钉和螺母
- 尤其适用于多轴机床，可保证姊妹刀具的长度一致性

Length adjustment for shrink fit chucks without back-up screw, e. g. Mini Shrink

- Fast, repeatable length adjustment of the total tool assembly with stop pin
- Adjustment with set screw and counter nut
- Integrated in chuck support, thus very space-saving
- Easy handling by turning of set screw and counter nut
- Application suitable also at multi-spindle machines for repeatable length presetting of twin tools



图片显示：快速长度预调装置和支撑座搭配使用（发货时不含支撑座）

Picture shows: Quick Set with base holder (Base holder not included in delivery)

锥柄尺寸/For taper size

订货号/Order No.

- SK/BT40	80.136.240
- HSK-E25	80.136.325
- HSK-E32	80.136.332
- HSK-E40	80.136.340
- HSK-E50	80.136.350
- HSK-A63	80.136.363
- PSC 40	80.136.440
- PSC 50	80.136.450
- 适合于基本型/经济型/经济增强型热缩机的支撑座/Base holder for Power Clamp Basic/Economic/Economic Plus	80.155.01
- 止动杆/Pin L = 125 mm	80.136.003
- 止动杆/Pin L = 150 mm	80.136.001
- 止动杆/Pin L = 175mm	80.136.004
- 止动杆/Pin L = 200mm	80.136.002
- 止动杆/Pin L = 270 mm	80.136.007
- 止动杆/Pin L = 310 mm	80.136.006

冷却转换套和冷却转换套毛坯

COOLING ADAPTER AND COOLING ADAPTER BLANKS



通过使用冷却转换套，各种形状的热缩刀柄都能被冷却。转换套插入冷却套内并锁紧，一起放置在热缩刀柄上。

- 与尺寸为 $\varnothing 14-16$ mm，和 $\varnothing 25-32$ mm 带锁紧装置的冷却套搭配使用。

By using cooling adapters all forms of shrink fit chucks can be cooled. The adapter is inserted into the cooling body and locked. Then it can be placed onto the shrink fit chuck.

- Cooling bodies for $\varnothing 14-16$ mm and $\varnothing 25-32$ mm with side lock

冷却套满足 DIN 标准刀柄
Cooling body for shrink fit chuck according to DIN

特殊刀柄需要冷却转换套
Cooling body with adapter for special shrink fit chucks

热缩延长杆需要冷却转换套
Cooling body with adapter for shrink fit chuck with extension

冷却转换套毛坯
客户自行加工，适合任何形状的热缩刀柄
Cooling adapter blanks for individual adaption to each shrink fit chuck by the user.

附件/Accessories	订货号/Order No.
- 搭配 $\varnothing 14-16$ mm 冷却套的转换套毛坯/Cooling adapter blanks for cooling body $\varnothing 14-16$ mm	80.105.14.0
- 搭配 $\varnothing 25-32$ mm 冷却套的转换套毛坯/Cooling adapter blanks for cooling body $\varnothing 25-32$ mm	80.105.16.0
- 搭配 $\varnothing 40-50$ mm 冷却套的转换套毛坯/Cooling adapter blanks for cooling body $\varnothing 40-50$ mm	80.105.19.3.0
- $\varnothing 12$ mm/ $\varnothing 16$ mm 延长杆用冷却转换套/Cooling adapter for extensions $\varnothing 12$ mm/ $\varnothing 16$ mm	80.105.14.1.1
- $\varnothing 20$ mm 延长杆用冷却转换套/Cooling adapter for extensions $\varnothing 20$ mm	80.105.14.1.2
- 直径 $\varnothing 3-5$ mm 的热缩刀柄用冷却转换套/Cooling adapter for shrink fit chucks $\varnothing 3-5$ mm	80.105.14.1.3
- 搭配冷却套 80.105.19.1，用于 $\varnothing 16$ mm 重型热缩刀柄的转换套/ Cooling adapter Heavy Duty $\varnothing 16$ mm for cooling body 80.105.19.1	80.105.19.3.1
- 搭配冷却套 80.105.19.1，用于 $\varnothing 20$ mm 重型热缩刀柄的转换套/ Cooling adapter Heavy Duty $\varnothing 20$ mm for cooling body 80.105.19.1	80.105.19.3.2
- 搭配冷却套 80.105.19.1，用于 $\varnothing 25$ mm 重型热缩刀柄的转换套/ Cooling adapter Heavy Duty $\varnothing 25$ mm for cooling body 80.105.19.1	80.105.19.3.3
- 搭配冷却套 80.105.19.1，用于 $\varnothing 32$ mm 重型热缩刀柄的转换套/ Cooling adapter Heavy Duty $\varnothing 32$ mm for cooling body 80.105.19.1	80.105.19.3.4
- 冷却转换套底座/Base for cooling adapters	80.105.14.1.99

迷你型热缩刀柄安装冷却套 MINI SHRINK SHRINK AND COOLING SLEEVES



迷你型热缩刀柄安装冷却套

- 防止迷你型热缩刀柄过热
- 延长刀柄使用寿命
- 方便安全的操作
- 冷却时配合 $\varnothing 6 - 8$ mm 标准冷却套使用

For shrinking and cooling of Mini Shrink chucks.

- Protect Mini Shrink chucks from overheating
- Extend lifetime of shrink fit chucks
- Secure and user friendly handling
- Cooling with standard cooling body $\varnothing 6 - 8$ mm

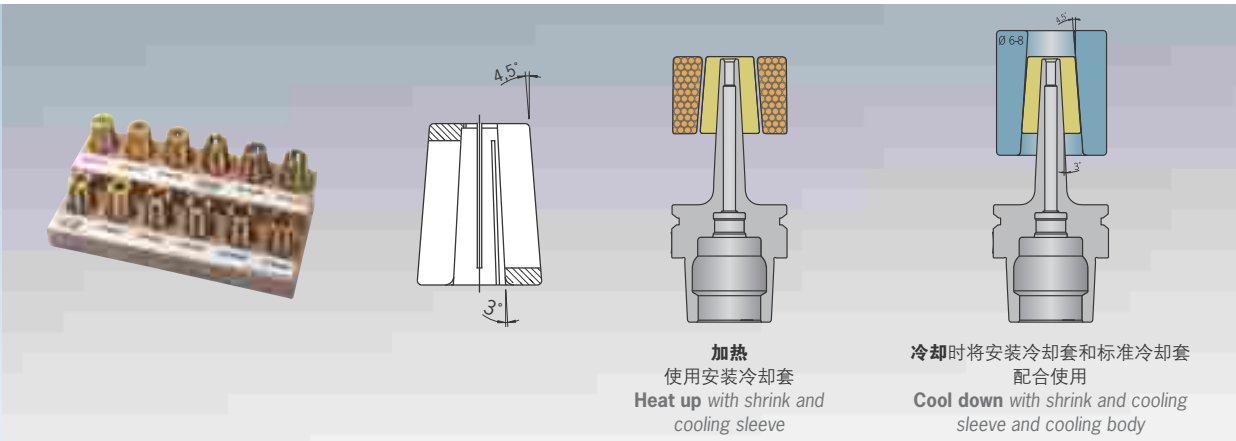

加热
使用安装冷却套
Heat up with shrink and cooling sleeve

冷却时将安装冷却套和标准冷却套配合使用
Cool down with shrink and cooling sleeve and cooling body

迷你型热缩刀柄的安装冷却套/Fitting sleeves for Mini Shrink chucks 订货号/Order No.

- 超细型/Extra slim									
尺寸/Size [mm]		$\varnothing 03$	$\varnothing 04$	$\varnothing 05$	$\varnothing 06$	$\varnothing 08$	$\varnothing 10$	$\varnothing 12$	
订货号/Order No.	80.105.14...	.2.01	.2.02	.2.03	.2.04	.2.05	.2.06	.2.07	
- 标准型/Standard									
尺寸/Size [mm]		$\varnothing 03$	$\varnothing 04$	$\varnothing 05$	$\varnothing 06$	$\varnothing 08$	$\varnothing 10$	$\varnothing 12$	$\varnothing 16$
订货号/Order No.	80.105.14...	.2.04	.2.08	.2.05	.2.09	.2.10	.2.11	.2.12	.2.16
- 基座/Base									80.105.14.2.99
- 套装的安装冷却套，带基座 (12个，直径3-12mm)/Set with base (12 pcs., diameter 3-12 mm)									80.105.14.2.00

带温控的智能冷却系统

TME COOLING SYSTEM WITH TEMPERATURE CONTROL

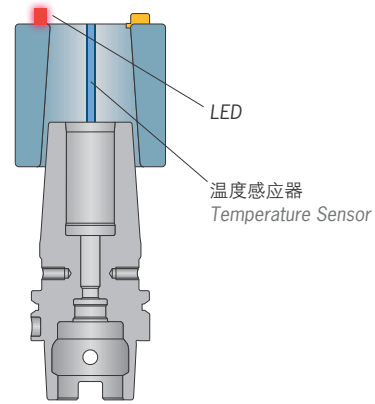

为了安全操作，在热缩刀柄的整个冷却过程中均有温度监控

- 铝合金本体内的传感器测量温度
- 正在冷却：红灯
- 冷却结束：绿灯
- 最大程度的降低了被烫伤的危害
- 专利的温控系统

(发明专利号码：EP 2 346 642 B1*)

Temperature control of the shrink fit chuck during the cooling process for a safe handling

- Sensor in aluminium body measures temperature.
- If temperature is too high: red light
- If temperature is at right level: green light
- Minimizing danger of injury due to hot chucks
- Patented temperature control

TME 温控系统/TME Cooling System

订货号/Order No.

- 13 kW 热缩机用温度控制冷却系统/TME Intelligent Cooling System for 13kW machines

按需提供/on request

- 20 kW 热缩机用温度控制冷却系统/TME Intelligent Cooling System for 20kW machines

按需提供/on request

热缩刀柄长度预调用支撑弹簧

TENSION SPRINGS FOR LENGTH PRESETTING FOR SHRINK FIT CHUCKS



长度调整用支撑弹簧
Tension spring for length presetting

- 放置在刀柄夹持孔内
- 刀具被弹簧支撑到止动位
- 刀柄内支撑螺钉可保留
- 适用于所有常规的热缩刀柄

- Spring is set into clamping bore
- Spring presses tool against stop disc
- Backup screw can remain in chuck
- Fits all common shrink fit chucks

支撑弹簧/Tension Springs		订货号/Order No.									
- 支撑弹簧/Tension spring		Ø 6	Ø 8	Ø 10	Ø 12	Ø 14	Ø 16	Ø 18	Ø 20	Ø 25	Ø 32
订货号/Order No. 85.830...		.06	.08	.10	.12	.14	.16	.18	.20	.25	.32
- 支撑弹簧套装 (每个尺寸10件), 包含抓取的工具											
Tension spring set (10 pcs. of each size) incl. grab											
85.830.00											

断刀取出装置 SHRINK-OUT DEVICE

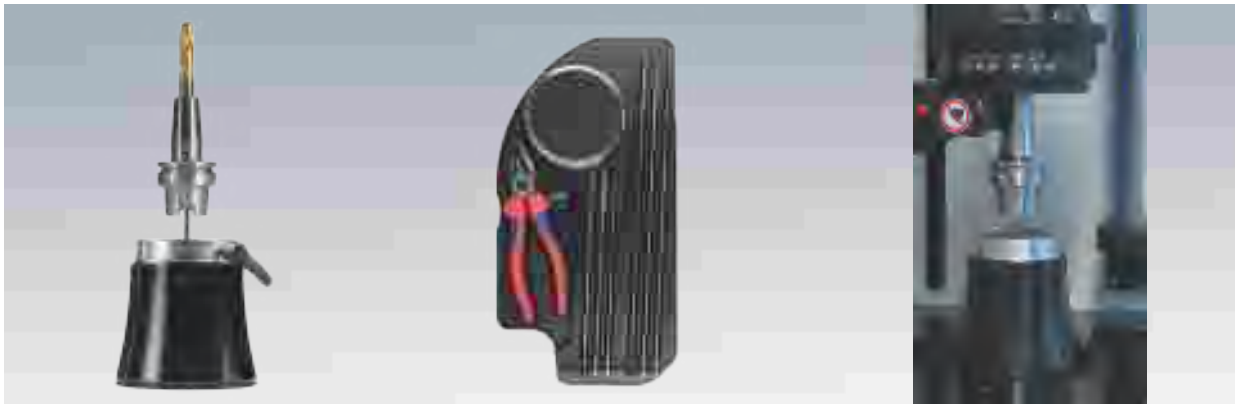

断刀取出装置

- 套装含1个底座和 6 根顶杆（两种长度各 3 种直径），不含钳子
- 橡胶底托保护刀柄
- 连同托盘可放入储物盒
- 适用于所有的热缩机

Shrink-out device for broken tools.

- Set with 1 base plate and 6 pins (3 diameters in 2 lengths each), without pliers
- Rubber plate for saving the chuck
- With drawer insert for craning box
- Suitable for all Power Clamp shrink fit machines

	订货号/Order No.
- 断刀取出装置/Shrink-out device	80.126.00
- 钳子/Combination pliers	80.107.00

附件/Accessories	订货号/Order No.
- 顶杆/Pin 160 mm x 2,3 mm	113027-0004
- 顶杆/Pin 160 mm x 4,7 mm	113027-0005
- 顶杆/Pin 160 mm x 6,0 mm	113027-0006
- 顶杆/Pin 275 mm x 2,3 mm	113027-0007
- 顶杆/Pin 275 mm x 4,7 mm	113027-0008
- 顶杆/Pin 275 mm x 6,0 mm	113027-0009

热缩刀柄用清洁毛刷 SHRINK FIT BRUSH

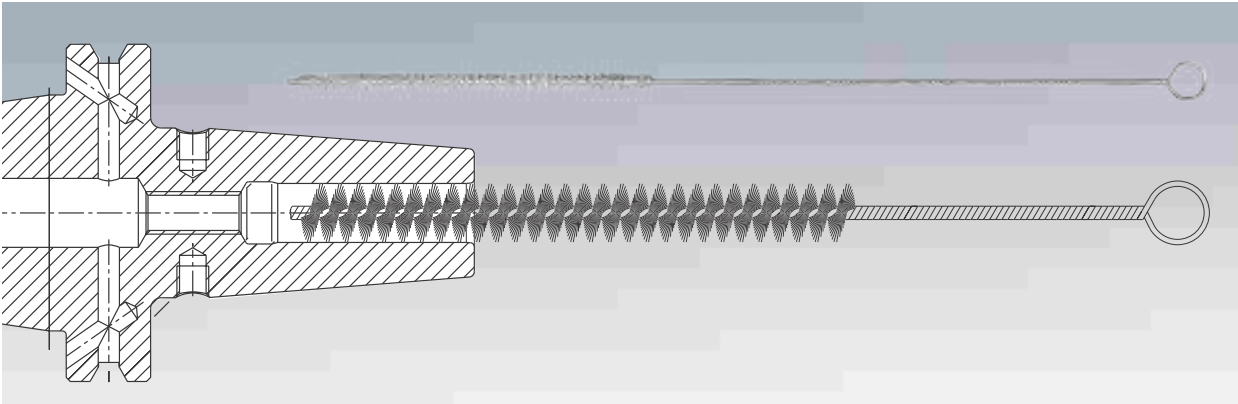

为了达到最好的热缩夹紧效果，清理热缩刀柄夹持孔的内部是必要的。这个清洁刷专门针对热缩刀柄设计，方便、快捷、有效地清洁热缩刀柄的夹持孔，可以和冷的溶剂一起应用（例如：制动器清洁剂），从而使刀柄一直处于高精度的工作状态下。

In order to achieve the best possible shrink fit connection, a grease free socket and shank is necessary. The cleaning can be done by a cold solvent (e.g. brake cleaner). An appropriate cleaning brush is necessary to clean the socket of the Shrink Fit Chuck.

	订货号/Order No.
- Ø [mm] 3	86.200.01
- Ø [mm] 3,5 / 4 / 4,5 / 5	86.200.02
- Ø [mm] 6 / 8	86.200.03
- Ø [mm] 10 / 12	86.200.04
- Ø [mm] 14 / 16	86.200.06
- Ø [mm] 18 / 20	86.200.07
- Ø [mm] 25	86.200.08

热缩刀柄用减径套

REDUCTION SLEEVES FOR SHRINK FIT CHUCKS

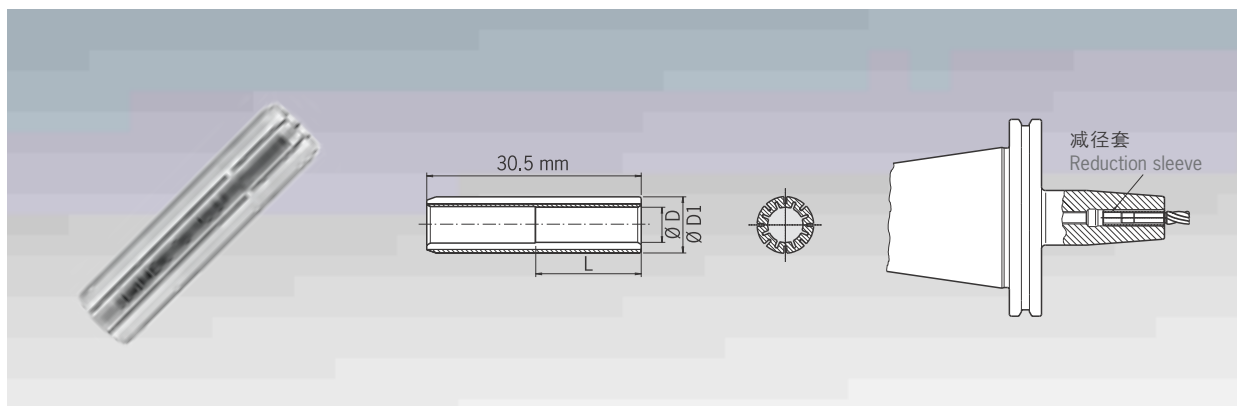
**使用:**

用于内孔为 $\varnothing 8$ mm 的热缩刀柄, 夹持小柄径刀具

第一步: 热装减径套入刀柄

第二步: 热装刀具入减径套

– 柄径 h6 公差范围的刀具

Use:

For clamping small shanks in chucks with 8 mm ID's.

First step: shrink sleeve into bore of chuck.

Second step: shrink tool shank in reduction sleeve.

– Shank tolerance h6

夹持范围/Clamping	$\varnothing D$	$\varnothing D1$	L	订货号/Order No.
– 夹持范围/Clamping \varnothing	2,5 mm	8 mm	7,5 mm	79.110.2.5
– 夹持范围/Clamping \varnothing	3,0 mm	8 mm	9,0 mm	79.110.03
– 夹持范围/Clamping \varnothing	3,5 mm	8 mm	10,5 mm	79.110.3.5
– 夹持范围/Clamping \varnothing	4,0 mm	8 mm	12,0 mm	79.110.04
– 夹持范围/Clamping \varnothing	4,5 mm	8 mm	13,5 mm	79.110.4.5
– 夹持范围/Clamping \varnothing	5,0 mm	8 mm	15,0 mm	79.110.05
– 夹持范围/Clamping \varnothing	5,5 mm	8 mm	16,5 mm	79.110.5.5

废气吸收装置 AUXILIARY FUME EXTRACTION UNIT



废气吸收装置用来吸收和过滤加热过程中产生的气体。

Auxiliary fume extraction unit to remove and filter vapours, which are produced during the shrink process.

为了提高装刀过程的可靠性，我们建议使用翰默的系统工具车，并在上面安装废气吸收装置。

For process reliable functionality we recommend the assembly of the extraction unit directly at a HAIMER system cart.

废气吸收装置/ Auxiliary fume extraction unit	热缩机机型/ Shrink fit machine Power Clamp	订货号/ Order No.
适用于线圈/for coil		
- VS32-H/M	Comfort (i4.0)/Comfort NG/Preset (NG/i4.0)/Profi Plus NG	80.101.02NG.01
- VS32-H	Premium Plus	80.101.02NG.02
- VS32-M	Premium Plus	80.101.03NG.02
- VS32-S	Premium i4.0/Sprint i4.0	80.101.03NG.03
- V2008	Economic/Economic Plus/Comfort	80.151.00.01
- 13 kW HD/20 kW	Economic Plus NG/Comfort NG/Preset NG (i4.0)	80.151.10.01

* 废气吸收装置的型号取决于热缩机和线圈的类型。有的热缩机可以选配 2 种线圈，例如 NG 舒适型热缩机 Comfort NG 可选配 VS32-H/M 和 13 KW HD 重型线圈分别用于柄径 3-32mm 的刃具和柄径大于 32mm 的刃具，那么对应的废气吸收装置也是不同的。如有疑问请咨询翰默公司人员。

13 KW HD 重型线圈升级套装 UPGRADE KIT 13 KW HD COIL



适用于直径达 Φ 50mm 的重型热缩刀柄

For shrinking of Heavy Duty Shrink Chucks up to Φ 50 mm.

用途:

适用于直径达 Φ 50 mm 的重型热缩刀柄

发货时包含:

- 13kw HD 重型线圈
- 线圈底座
- 止动盘组
- 最新的软件
- Φ 40-50 mm 的 HD 重型冷却套
- 冷却管套装
- 各种冷却管接头
- 选项: 冷却转换套

仅适用于 **2012 年 1 月** 以后生产的经济型/ NG 经济型/
经济增强型/NG 经济增强型 / 特殊配置经济增强型/
舒适型/NG舒适型/NG强力型/NG测量型/超级增强型/
工业 4.0气冷经济型/工业 4.0气冷舒适型/
工业 4.0舒适型/工业 4.0 测量型/工业 4.0 超级型/
工业 4.0 全能型热缩机

Use:

For shrinking of Heavy Duty Shrink Chucks up to Φ 50 mm.

Delivery includes:

- 13 kW HD coil
- Coil base
- Set of stop discs
- Latest software
- HD cooling body Φ 40-50 mm
- Hose set for HD cooling body
- Coolant Manifold Connection
- Optional: cooling adapter for HD cooling body

Upgrade only possible for existing shrink fit machine
Power Clamp Economic/Economic NG/Economic Plus/
Economic Plus NG/Special Edition/Comfort/Comfort NG/Profi
Plus NG/Preset NG/Premium Plus/Comfort i4.0/Preset i4.0/
Premium i4.0/Sprint i4.0/Air i4.0 Eco/Air i4.0 Comfort that
were produced after **01/2012**.

订货号/Order No.

- 13 kW HD 重型线圈升级套装/Upgrade Kit 13 kW HD coil

80.151.30.10

止动盘 STOP DISCS

夹持范围/Clamping Ø D [mm]	止动盘/Stop discs	订货号/Order No.
N29 线圈用(NANO 纳米型热缩机)/for coil N29 (Power Clamp Nano)		
- 3 - 5 mm		80.162.03
- 6 - 8 mm		80.162.06
- 10 - 16 mm		80.162.10
- 10 - 12 mm		80.162.10.2
-	N29 线圈用止动盘套装/Stop disc set N29	80.162.00
- 3 - 5 mm	开裂式止动盘/stop disc splitted	80.162.03.1
- 6 - 8 mm	开裂式止动盘/stop disc splitted	80.162.06.1
- 10 - 16 mm	开裂式止动盘/stop disc splitted	80.162.10.1
- 10 - 12 mm	开裂式止动盘/stop disc splitted	80.162.10.2.1
13 kW V2008 标准线圈用/for 13 kW coil V2008		
- 3 - 5 mm		80.152.03
- 6 - 12 mm		80.152.06
- 14 - 16 mm		80.152.14
- 18 - 20 mm		80.152.18
- 25 - 32 mm		80.152.25
-	13 kW V2008 标准线圈用止动盘套装/Set of stop discs 13 kW V2008	80.152.00
- 3 - 5 mm	开裂式止动盘/stop disc splitted	80.152.03.1
- 6 - 12 mm	开裂式止动盘/stop disc splitted	80.152.06.1
- 14 - 16 mm	开裂式止动盘/stop disc splitted	80.152.14.1
- 18 - 20 mm	开裂式止动盘/stop disc splitted	80.152.18.1
- 25 - 32 mm	开裂式止动盘/stop disc splitted	80.152.25.1
-	13 kW V2008 标准线圈用止动盘套装(开裂式) / Set of stop discs 13 kW V2008 (splitted)	80.152.00.1
- 6 - 12 mm	超短标准型和超短强力型热缩刀柄用止动盘/ Stop disc for ultra short shrink fit chucks and ultra short Power Shrink Chucks	80.152.06.2
- 14 - 20 mm	超短标准型和超短强力型热缩刀柄用止动盘/ Stop disc for ultra short shrink fit chucks and ultra short Power Shrink Chucks	80.152.14.2
- 25 - 32 mm	超短标准型和超短强力型热缩刀柄用止动盘/ Stop disc for ultra short shrink fit chucks and ultra short Power Shrink Chucks	80.152.25.2
20 kW 和 13 kW HD 重型线圈用/for 20 kW coil and 13 kW HD coil		
- 16 - 20 mm		80.151.10.42
- 20 - 32 mm		80.151.10.41
- 40 - 50 mm		80.151.40.40
- 16 - 20 mm	20 kW/13 kW HD 开裂式止动盘/ stop disc 20 kW/13 kW splitted	80.151.10.42.1
- 25 - 32 mm	20 kW/13 kW HD 开裂式止动盘/ stop disc 20 kW/13 kW splitted	80.151.10.41.1
- 40 - 50 mm	20 kW/13 kW HD 开裂式止动盘/ stop disc 20 kW/13 kW splitted	80.151.40.40.1



用途:

可换式止动盘将线圈准确定位在刀柄的上方



Use:

Changeable stop discs for positioning the coil above the chuck.



如需更详细的产品和技术信息
请登录翰默公司网站：
www.haimer.cn

